



**≡ - Facade LITE**

Plug & Power Up! - As easy as it sounds

Energy Generating Building Materials:  
eFacade LITE Product Datasheet

 **MITREX™**  
mitrex.com

## ⚡ Plug & Power Up with eFacade LITE

eFacade LITE by Mitrex is a pre-engineered solar facade system with advanced building-integrated photovoltaic technology (BIPV) created to accelerate solar adoption without compromising performance. A ventilated rainscreen system with a hidden extruded aluminum profile encasing a layer of high-efficiency solar cells and a glass facing, each module is a powerhouse of energy.

Designed for projects seeking rapid deployment, lower costs, and simplified electrical integration, LITE modules feature a built-in PowerBar that enables plug-and-play wiring on site. With two module sizes and five color options, eFacade LITE delivers energy performance in a system that's optimized for streamlined delivery and long-term durability. It's the ideal solution for retrofit projects, budget-conscious developments, or buildings that require simplicity and speed.

### 🔌 Plug & Power Up

Offers high energy output—up to 18W/SF—without compromising durability. With pre-engineered wiring, it features a plug-and-power setup that removes the need for additional solar system design or engineering.

### 🏠 Colors & Sizes

Available in five colors with a satin glass finish, this solution provides a minimalist aesthetic. Available in two standardized sizes and 11 module layouts preserving design flexibility.

### ☔ Rainscreen System

Designed as a ventilated rainscreen, it improves thermal performance, reduces moisture, and boosts the building envelope's durability and efficiency.

### ♻️ Sustainability

Supporting a lower-carbon built environment, it generates clean energy and is made with recyclable, low-embodied carbon materials.

### 🛡️ Certifications

Independently tested and certified, it meets key international standards for wind and impact resistance, as well as UL safety requirements.

### 🔥 Fire Safety

Built with non-combustible glass and a tested backing system, it meets strict global fire safety standards, including EN 13501 A2-s1,d0 and NFPA 285.

### 🌞 Performance

Rated for extreme conditions, it withstands UV exposure, heavy rain, high winds, and freeze-thaw cycles, operating reliably from -40°C to +85°C.

### 🔧 Maintenance

Engineered for longevity, it features self-cleaning glass and durable surface treatments, requiring minimal maintenance over a 25-year power performance warranty.

### 💰 Incentives

Projects may qualify for sustainability incentives such as government rebates, green energy grants, and low-cost financing across North America.

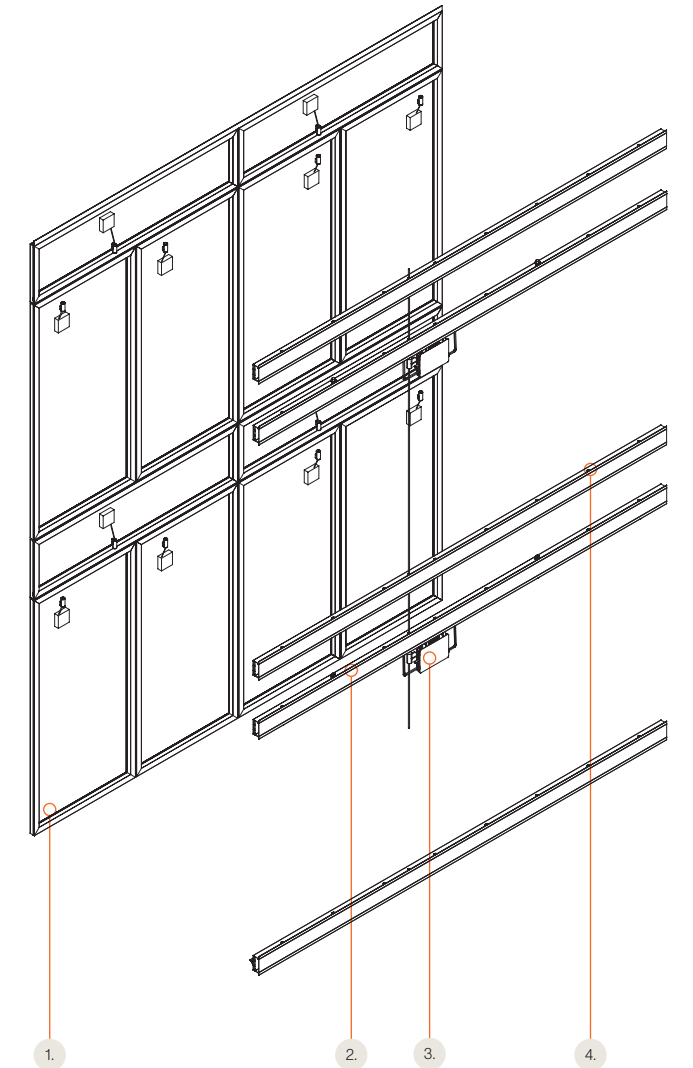

### eFacade LITE Details

- 1. ⚡ SunTile (Solar Modules)
- 2. Power Bar
- 3. Microinverter
- 4. Support Bar

## SunTile Electrical And Mechanical Data

For Large Standard Module 1854×922×34mm (72.9×36.2×1.3in)

● Test	● Specification	● Engineering Drawing
<b>Test Conditions</b>	<b>STC</b>	
Module Power (Pmax)	170 - 315 W	
Maximum Power Voltage (Vpmax)	41.0 - 41.3 V	
Maximum Power Current (Ipmax)	4.15 - 7.63 A	
Open Circuit Voltage (Voc)	49.2 - 49.6V	
Short Circuit Current (Isc)	4.38 - 8.05 A	
Module Efficiency	9.9 - 18.4%	
Cell Efficiency	23.5% - Monocrystalline Solar Cell	
Maximum System Voltage (VDC)	1000V (IEC/UL)	
Max Series Fuse Rating	20A	
Power & Other Electrical Specification Tolerance	5%	
Application Classification	Class A	
Measurement Conditions: STC 1000 W/m <sup>2</sup> - AM 1.5 - Temperature 25°C		

● Mechanical Properties	● Metric	● Imperial
Module Weight	32.3kg	71.2lbs
Dimensions (H x L x D)	1854 x 922 x 34mm	72.9 x 36.2 x 1.3in
Maximum Surface Load (Wind / Snow)	2400Pa rear load / 2400Pa front load	50psf rear load / 50psf front load
Design Load	1600Pa rear load / 1600Pa front load	33psf rear load / 33psf front load
Hail Impact Resistance	ø 25mm at 83 km/h	ø 1in at 51.6 mph
Cells	128 [2 x (2 x 32)] Mono-crystalline M12 quarter cell (210.0 x 52.5mm)	128 [2 x (2 x 32)] Mono-crystalline M12 quarter cell (8.26 x 2.07in)
Glass	6mm tempered glass, high transmittance, anti-reflective coating	0.24in tempered glass, high transmittance, anti-reflective coating
Backsheet	High durability, UV resistant, PV backsheet	
Back Support	Black anodized aluminum frame	
Junction Box	IP68 rated, TUV and UL certified	
Fire Rating	Spread of Flame A, Burning Brand C	

● Temperature Ratings	
Temperature Coefficient Isc	0.05% /°C
Temperature Coefficient Voc	-0.28% /°C
Temperature Coefficient Pmax	-0.35% /°C
Nominal Module Operating Temperature	45 ± 3°C
Operating Temperature	-40°C ~ +85°C

## SunTile Electrical And Mechanical Data

For Small Standard Module 1854×456×34mm (72.9×18.0×1.3in)

● Test	● Specification	● Engineering Drawing
<b>Test Conditions</b>	<b>STC</b>	
Module Power (Pmax)	85 - 160 W	
Maximum Power Voltage (Vpmax)	41.0 - 41.3 V	
Maximum Power Current (Ipmax)	2.07 - 3.87 A	
Open Circuit Voltage (Voc)	49.2 - 49.6 V	
Short Circuit Current (Isc)	2.19 - 4.03 A	
Module Efficiency	10.0 - 18.9 %	
Cell Efficiency	23.5% - Monocrystalline Solar Cell	
Maximum System Voltage (VDC)	1000V (IEC/UL)	
Max Series Fuse Rating	20A	
Power & Other Electrical Specification Tolerance	5%	
Application Classification	Class A	
Measurement Conditions: STC 1000 W/m <sup>2</sup> - AM 1.5 - Temperature 25°C		

● Mechanical Properties	● Metric	● Imperial
Module Weight	16.9kg	37.2lbs
Dimensions (H x L x D)	1854 x 456 x 34mm	72.9 x 18.0 x 1.3in
Maximum Surface Load (Wind / Snow)	2400Pa rear load / 2400Pa front load	50psf rear load / 50psf front load
Design Load	1600Pa rear load / 1600Pa front load	33psf rear load / 33psf front load
Hail Impact Resistance	ø 25mm at 83 km/h	ø 1in at 51.6 mph
Cells	64 [32 x 2] Mono-crystalline M12 quarter cell (210.0 x 52.5mm)	64 [32 x 2] Mono-crystalline M12 quarter cell (8.26 x 2.07in)
Glass	6mm tempered glass, high transmittance, anti-reflective coating	0.24in tempered glass, high transmittance, anti-reflective coating
Backsheet	High durability, UV resistant, PV backsheet	
Back Support	Black anodized aluminum frame	
Junction Box	IP68 rated, TUV and UL certified	
Fire Rating	Spread of Flame A, Burning Brand C	

● Temperature Ratings	
Temperature Coefficient Isc	0.05% /°C
Temperature Coefficient Voc	-0.28% /°C
Temperature Coefficient Pmax	-0.35% /°C
Nominal Module Operating Temperature	45 ± 3°C
Operating Temperature	-40°C ~ +85°C

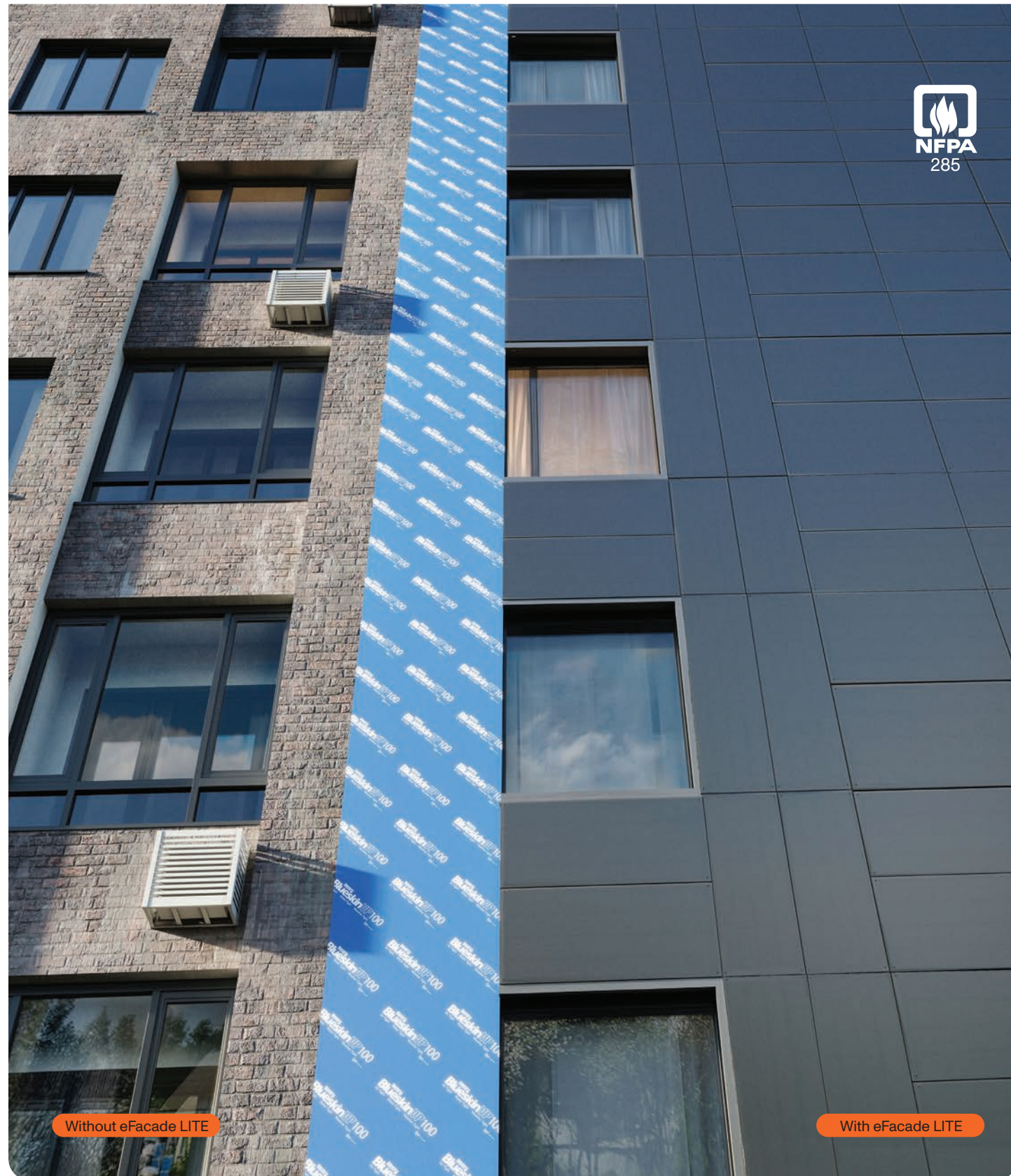

## eFacade LITE Crafted For Perfection

### eFacade LITE Package Components

Each eFacade LITE package comes with 150 SQFT of material and the following components. The amount of the SunTiles may vary depending on the layout.



### Lifetime Warranty

- Mitrex solar facade products physically last the lifetime of the building and beyond as a building envelope product.
- The warranty guarantees that the energy generation will have a minimum energy output of 80% by year 25. However, energy generation will continue after the warranty period ends for as long as the modules are on the wall.
- Our lifetime warranty ensures reliable, durable facades as the modules require minimal maintenance and there is zero module replacement needed for the building lifetime.

### eFacade LITE Colours Available

Mitrex eFacade LITE is available in five clean, neutral color tones to blend with any project. These curated options are designed to complement a wide range of architectural materials such as aluminum modules, GFRC, EIFS, and ACM. Whether your design calls for a bold contrast or understated elegance, LITE's palette offers the flexibility to enhance visual cohesion across facades.

Core Black ⚡ 18W/SQFT ⚡ 2.5 kW*	Blackout ⚡ 16W/SQFT ⚡ 2.2 kW*	Nobel Grey ⚡ 10W/SQFT ⚡ 1.3 kW*	Storm Grey ⚡ 13W/SQFT ⚡ 1.8 kW*	Cassia ⚡ 14W/SQFT ⚡ 2.0 kW*

\*These system outcomes are based on one standard package consisting of 150 SQFT.

**ORDER A FREE SAMPLE!**  
Experience the look and feel of our solar cladding. Scan the QR code or visit [www.mitrex.com](http://www.mitrex.com) to order your free Mitrex sample today.

### Module Size Capabilities

Mitrex eFacade LITE offers two standard sizes that can be seamlessly integrated with other modules of the same size or between the two sizes.

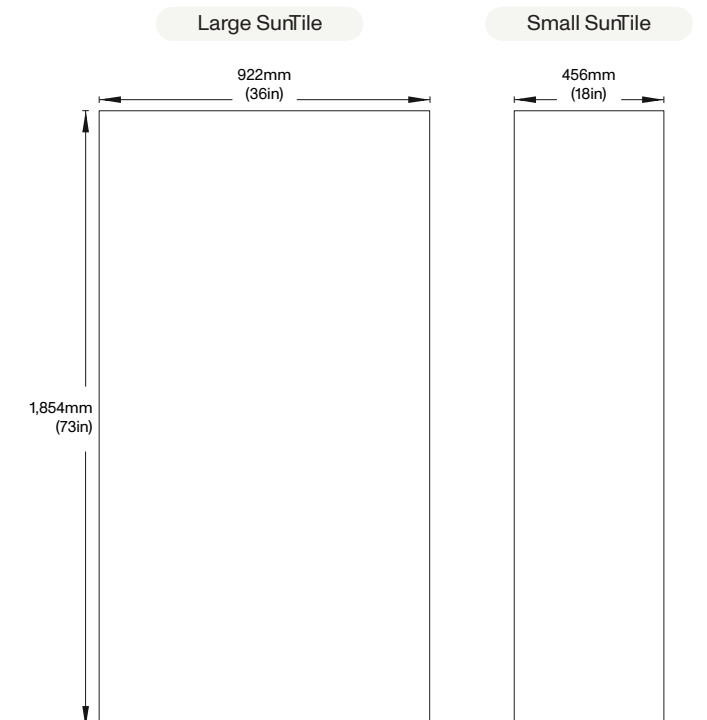

## SunTile (Solar Module) Details

### Solar Glass Mechanical Data

	Imperial	Metric
Glass Type	Satin Glass	
Thickness	0.24 ± 0.012in	6 ± 0.3mm
Weight	3.07lb/SQFT	15.0kg/m <sup>2</sup>
Dimensional Tolerance	± 0.04in	± 1.0mm
Density	0.09lbs/in <sup>3</sup>	2.5gm/cm <sup>3</sup>
Corner	Radius, Chamfer or cut (0.04-0.16in)	Radius, Chamfer or cut (1.0-4.0mm)
Overall Bow / Warp <small>(EN 12150-1:2015)</small>	0.16in / 39.37in	4.0mm/M / 990mm/M
Local Warp <small>(EN 12150-1:2015)</small>	0.002in / 11.81in	0.5mm / 300mm/M
Bending Strength <small>(EN 12150-1:2015) (0.23in / 6mm)</small>	685.21lbs/in	120N/mm
Iron Content <small>(ASS)</small>	<120ppm	
Edge	At least seamed	
Scratch Hardness <small>(Mohs)</small>	5	
Fragmented Particles in 50x50mm <small>(If Tempered) (EN 12150-1:2015)</small>	Min 40 pcs	

### Solar Glass Facing Specification

	Certification	Imperial	Metric
Density	ASTM C729	158lb/ft <sup>3</sup>	2,530kg/m <sup>3</sup>
Absorption By Wt.	ASTM C373	0%	0%
Compressive Strength	-	150,000psi	1,000MPa
Flexural Strength <small>(Dry)</small>	ASTM C158	8,700psi	60MPa
Modulus Rupture	ASTM C158	5,950psi	41MPa
Hardness	ASTM C730	570KHN	

For further mechanical information about solar glass, please check Mitrex solar glass datasheet.

### Module Extruded Aluminum Profile (EAP) Mechanical Data

	Imperial	Metric
Dimensions (H x L)	1.22 x 1.42in	31.1 x 36.1mm
Weight	0.29lb/ft	0.43kg/m
Elastic Modulus	10,000 psi	69 GPa
Tensile Strength	31,000 psi	214 MPa
Shear Strength	22,000 psi	152 MPa
Material	Aluminum Alloy	

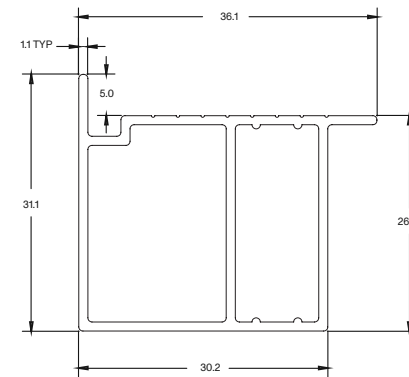

Test	Rating
Smoke And Flame Spread (ASTM E84)	Class A
Sound Transmission Coefficient (ASTM E90)	34

## System Components Details

### Anchor Plate Mechanical Data

	Imperial	Metric
Dimensions (H x L x D)	1.71 x 2.0 x 0.19in	43.6 x 50.8 x 4.9mm
Weight	0.04lb	20.3g
Elastic Modulus	10,000 psi	69 GPa
Tensile Yield Strength	40,000 psi	275 MPa
Shear Yield Strength	24,000 psi	165 MPa
Material	Aluminum Alloy	

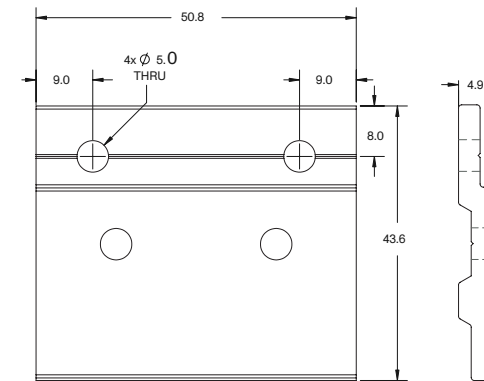

### Microinverter Details

#### Mechanical Data

	Imperial	Metric
Ambient Temperature Range	-40 to +149 F°	-40 to +65 C°
Enclosure Rating	Outdoor - IP67 (NEMA6)	
Cooling	Natural Convection - No Fans	

#### Input Data (DC)

	Model 480V
Commonly Used Module Power (W)	50 to 1000 +
Maximum Input Voltage (V)	65
MPPT Voltage Range (V)	16 - 60
Start-up Voltage (V)	22
Maximum Input Current (A)	4 x 30
Maximum Input Short Circuit Current (A)	4 x 40
Number Of MPPTs	4
Number Of Inputs Per MPPT	1

<sup>1</sup> Nominal voltage/frequency range can vary depending on local requirements. <sup>2</sup> Refer to local requirements for exact number of microinverters per branch

### Power Bar (Mounting Rail and Cap) Mechanical Data

	Imperial	Metric
Dimensions (H x L x D)	2.44 x 4.8 x 72.2in	62 x 122.3 x 1,834mm
Weight	1.24lb/ft	1.84kg/m
Elastic Modulus	10,000 psi	69 GPa
Tensile Yield Strength	31,000 psi	214 MPa
Shear Yield Strength	22,000 psi	152 MPa
Material	Aluminum Alloy	

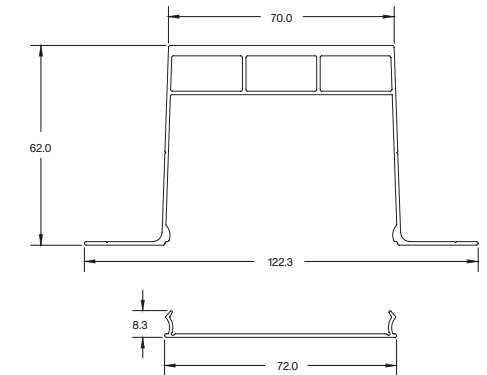

#### Efficiency

	Model 480V
CEC Peak Efficiency	>= 96.5%
Normal MPPT Efficiency	>= 99.7%
Night Power Consumption (mW)	< 50

#### Output Data (AC)

	Model 480V
Peak Output Power	1900
Maximum Continuous Output Power (A)	1900
Maximum Continuous Output Current (A)	2.28
Normal Output Voltage/Range (V) <sup>1</sup>	480/422 - 528
Nominal Frequency/Range (Hz)	60/55 - 65
Power Factor (Adjustable)	> 0.99 default 0.8 leading ... 0.8 lagging
Total Harmonic Distortion	< 3%
Maximum Units Per 8AWG Branch (45A) <sup>2</sup>	15

## Testing And Certifications Details

Category	Test Name	Test Specification	Result
Acoustic	Sound Transmission Loss	ASTM E90	Sound Transmission Rating: CladiShield Rainscreen: 34; Claditized Unitized: 35; CladiFab Prefab: 55
	Salt Spray Resistance	ASTM B117-16	No deleterious effects.
Environmental	Air Leakage Resistance	ASTM E283-04 (2012)	LITE, PRO, CladiShield: Qinf = 0.031 cfm/ft <sup>2</sup> or 0.155 L/s-m <sup>2</sup> at 300 Pa; Qexf = 0.024 cfm/ft <sup>2</sup> or 0.122 L/s-m <sup>2</sup> at 300 Pa
	Water Penetration Resistance	ASTM E331	No water infiltration at 15 psf or 720 Pa
	Dust and Sand Test	IEC 60068-2-68	No visual anomalies
	Cyclic Salt Mist Exposure	IEC 61701 (2011)	No significant corrosion or ingress
	Moist Ammonia Exposure	IEC 62716 (2013)	No significant corrosion or ingress
Fire Safety	Standard Methods of Fire Endurance Tests of Building Construction Materials	ASTM E119 / CAN/ULC S101	LITE, PRO, CladiShield: 1 hour fire exposure; Passed.
	Exterior Wall Assembly Fire Test	CAN/ULC S134	Passed
	Fire Classification	EN13501	Rating: A2-s1,d0
	Tunnel Test	ASTM E84	FSI = 10; SDI = 200; Class A
	Non-Combustibility (ASTM E136)	ASTM E136	Passed
	Multi-Story Fire Test	NFPA 285	Passed
	Surface Burning Characteristics	CAN/ULC S102	FSR = 0; Class A
	Non-Combustibility (CAN/ULC S114)	CAN/ULC S114	Passed
	Combustibility Parameters (Cone Calorimeter)	CAN/ULC S135	Passed NBCC 2015 requirements
	Cyclic Pressure Loading	ASTM E1886 / TAS 203	Passed. Over 3,500 positive and negative pressure cycles were applied at ± 2880 Pa (60 psf), equivalent wind load of 165 mph.
Impact / Safety	Structural Performance by Uniform Static Air Pressure Difference	ASTM E330	LITE, PRO, CladiShield: Design Load at +/-80 psf or +/- 3840 Pa; No Failure
	Linear Thermal Expansion	ISO 10545-8	11.28 × 10 <sup>-6</sup> /°C
PV Quality	Terrestrial Photovoltaic (PV) Modules - Design Qualification and Type Approval	IEC/UL 61215	Passed
	Potential-Induced Degredation (PID)	IEC TS 62804-1:2025	Passed
	Standard for Photovoltaic (PV) Module Safety	IEC/UL 61730	Passed
PV Safety			



## eFacade LITE Layout Options

eFacade LITE Linear Precision

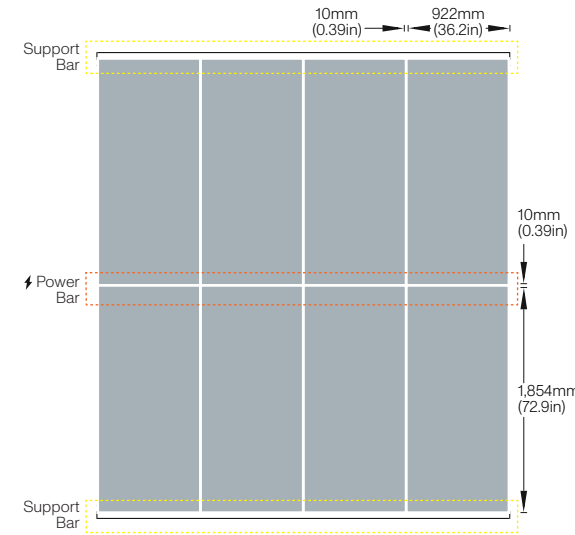

eFacade LITE Horizon Grid

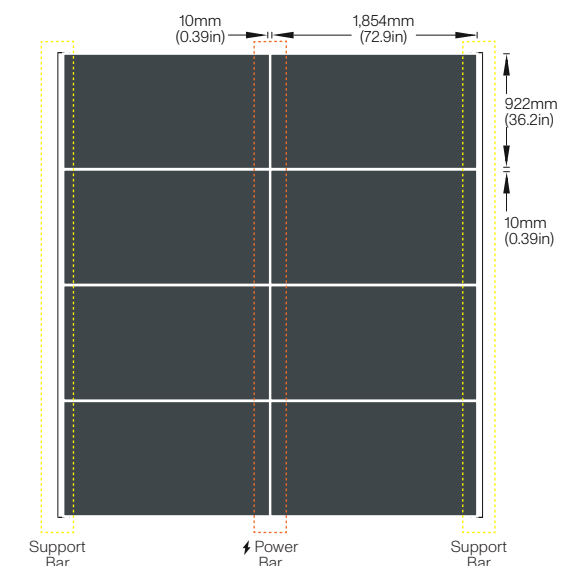

eFacade LITE Half Linear Precision

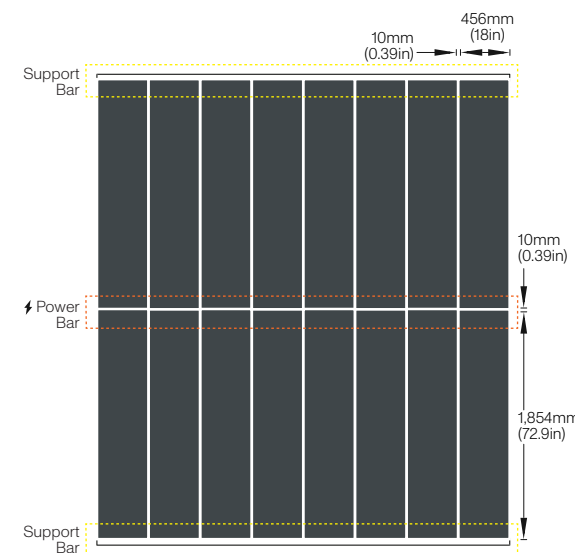

eFacade LITE Half Horizon Grid

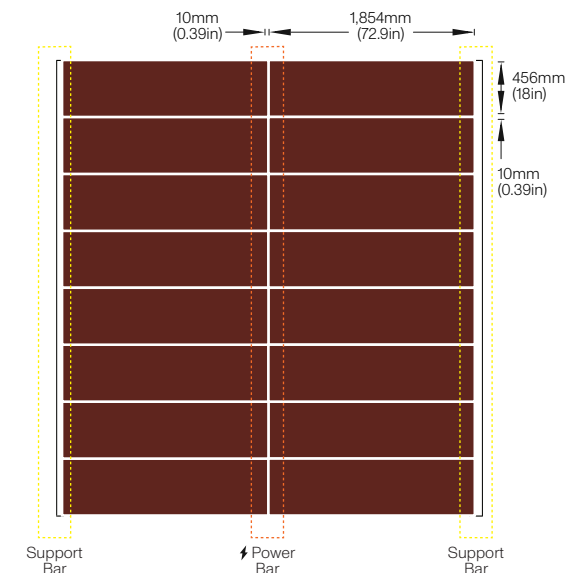

## eFacade LITE Layout Options

eFacade LITE Dual Linear Precision

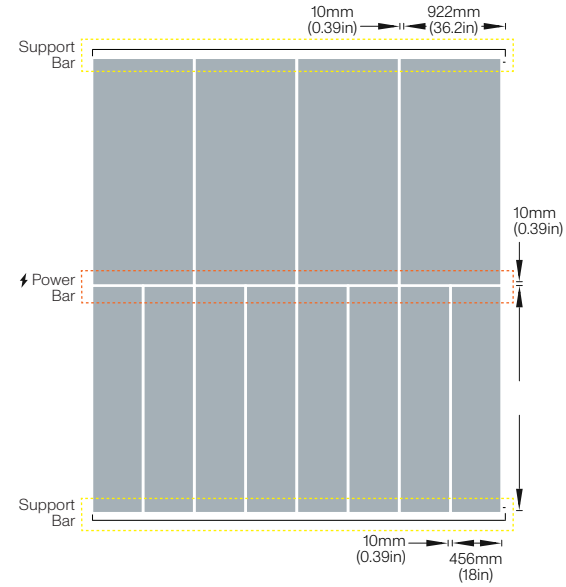

eFacade LITE Dual Horizon Grid

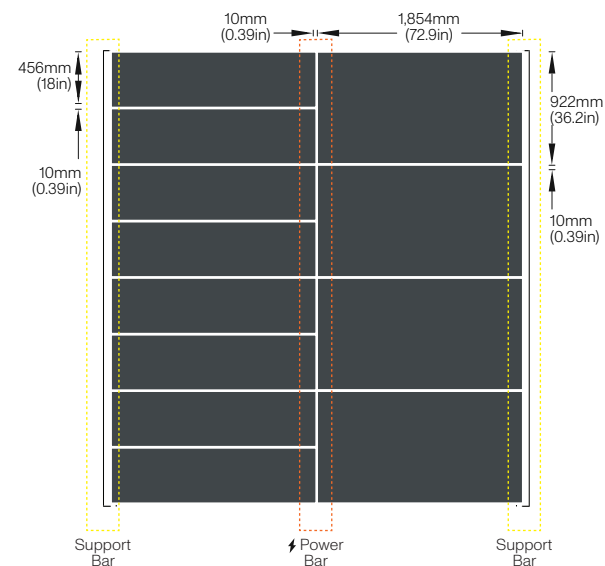

eFacade LITE Dual Linear Precision A

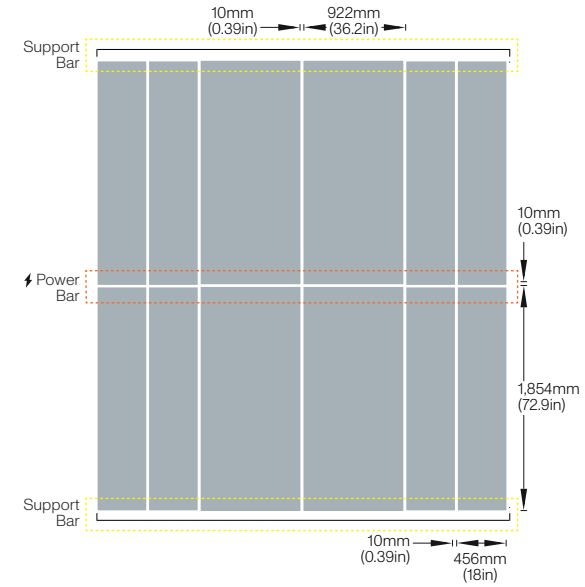

eFacade LITE Dual Linear Precision B

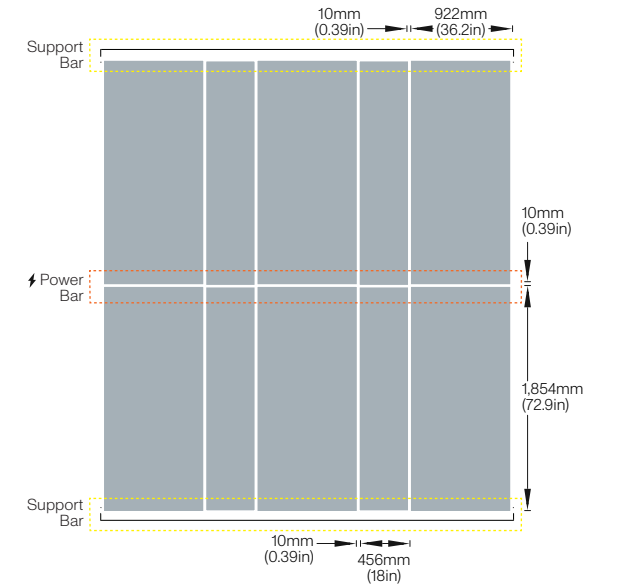

eFacade LITE Mixed Linear Precision

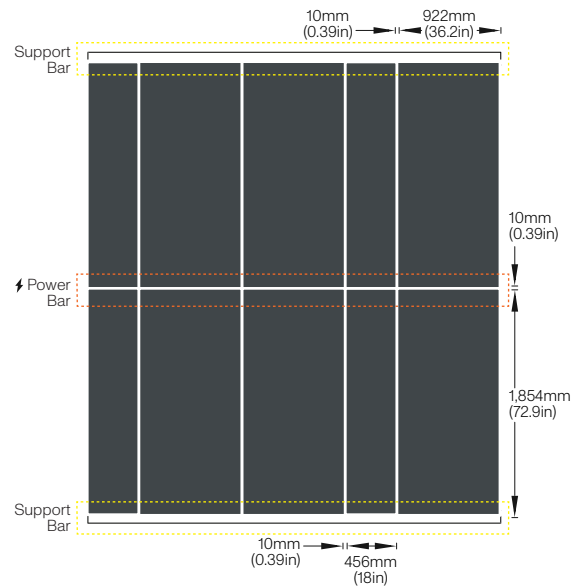

eFacade LITE Mixed Horizon Grid

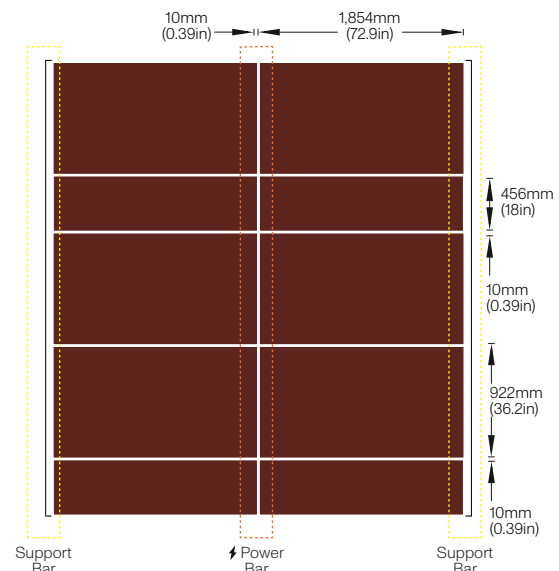

eFacade LITE Dual Linear Precision C

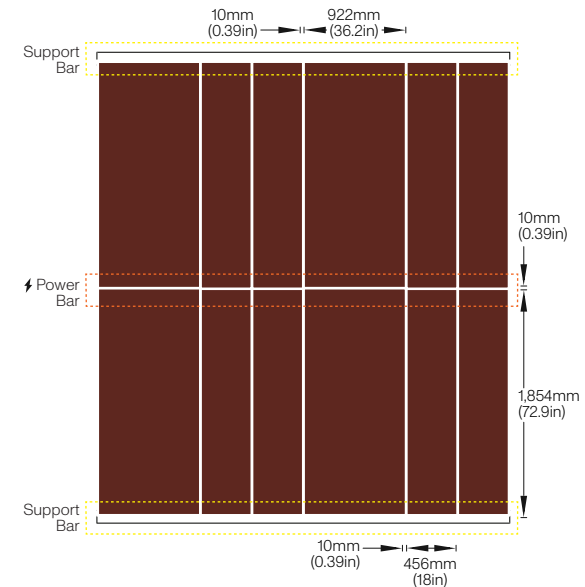

## eFacade LITE Electrical Connection

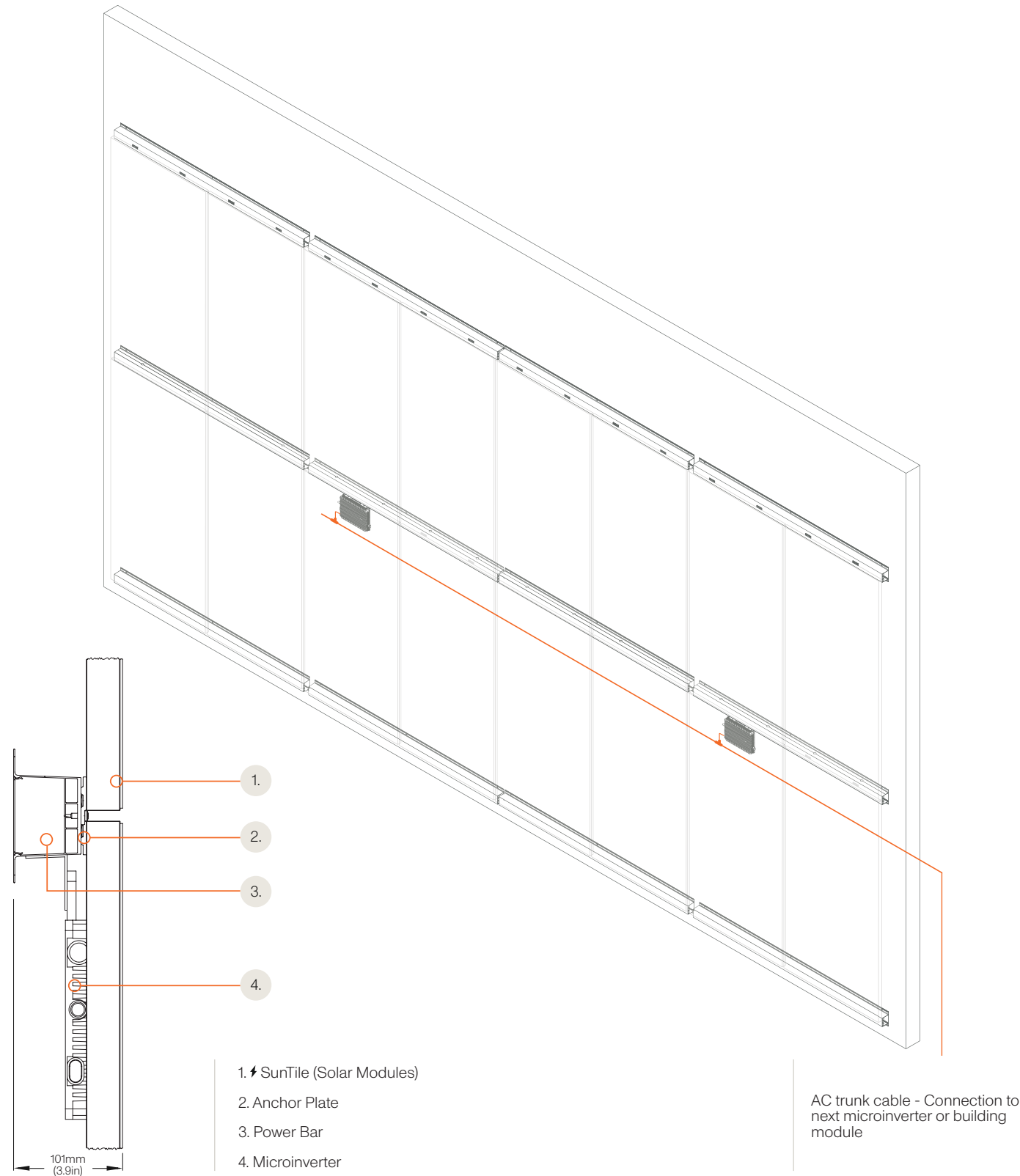

## eFacade LITE With FlexFit: Field-Adjustable Facade Modules

To ensure a clean and complete installation of the system, non-active filler modules (FlexFit) are available upon request. **These modules can be cut to size on site**, and are designed to integrate seamlessly with the eFacade LITE SunTile modules, allowing installation teams to adapt in real time while maintaining system integrity and facade continuity.

This flexibility ensures a consistent and professional appearance across the entire facade, regardless of the specific dimensions or geometry of the installation area.

**Note:** This material is delivered upon request - Ask Us!

## Features

### FlexFit: Adjustable On Site

Non-active LITE modules that can be cut on-site to fit any wall dimension, allowing you to complete every wall, corner and edge immediately.

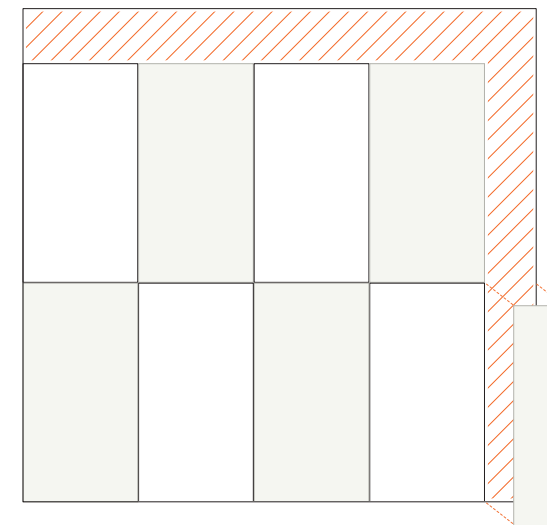

### Same Installation Method

Even when cut on site, eFacade LITE FlexFit modules follow the same installation method as standard ones, keeping the process simple, consistent, and familiar for installers.

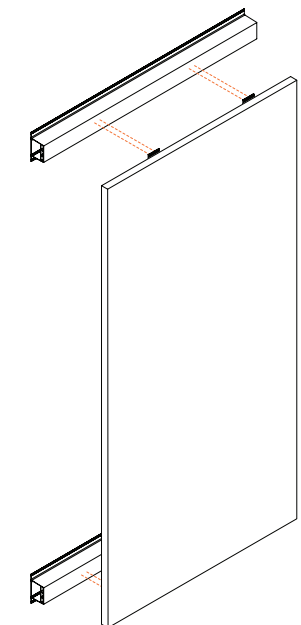

## Mitrex eFacade Products Comparison

Mitrex offers three distinct solar cladding solutions—eFacade LITE, eFacade PRO, and eFacade PRO+—each engineered to meet varying project needs in terms of design flexibility, performance, and scale.

The table below provides a detailed comparison across key features such as colors and finishes, sizing options, weight, system compatibility, and testing standards. Whether you're prioritizing affordability, customization, or advanced performance, this side-by-side overview will help you identify the best fit for your project.

	• eFacade LITE	• eFacade PRO	• eFacade PRO+
<b>Colors &amp; Patterns</b>	5 color options	48 color options	Unlimited customizable colors & patterns
	Finish: Satin glass Thickness: 0.24in (6mm)	Finish: Satin glass Thickness: 0.24in (6mm)	Finish: Super satin, satin, matte, glossy, wood grain, aqualite, and more. Thickness: 0.12-0.47in (3.2-12mm)
<b>Sizes &amp; Weight</b>	2 size options: 73 × 36 in (1854 × 922 mm) 73 × 18 in (1854 × 456 mm)	Custom sizes up to 80 × 39 in (2030 × 990mm).	Customizable single piece sizes up to 125 × 80 in (3,175 × 2,030mm). Preassembled pieces up to 420 inches (10.7m) long.
	Weight: 3.87 lb/SQFT (18.9 kg/sqm)	Weight: 3.84 lb/SQFT (18.8 kg/sqm)	Weight: 3.1 - 4.7 lb/SQFT (15.4-23.1 kg/sqm)
	Backing: Extruded aluminum profile with module thickness of 1.3in (34mm)	Backing: Extruded aluminum profile with module thickness of 1.3in (34mm)	Backing options: <u>Extruded aluminum profile with module thickness: 1.3in (34mm).</u>  <u>Aluminum honeycomb with module thickness:</u> • 1 in (25mm) honeycomb: 1.18in (30.2mm) - 1.23 in (33mm). • 2 in (50mm) honeycomb: 2.17in (55.2mm) - 2.28 in (58mm).
	Shapes: rectangle	Shapes: rectangle	Customizable Shapes: rectangle, triangle, circle, and more
<b>Systems</b>	Ventilated rainscreen system, eFacade LITE system	Ventilated rainscreen system (interlocking channel or anchor plate)	Customizable rainscreen, unitized or prefabricated system options
	System Thickness: 3.9in (101mm)	System Thickness: 1.5 in (39mm) - 2.32 (59mm)	System Thickness: 1.42 in (36mm) - 4.33in (110mm)
	MOQ of 5,000 SQFT (464.5 sqm)	MOQ of 5,000 SQFT (464.5 sqm)	MOQ of 25,000 SQFT (2,322.5 sqm)
<b>Testing</b>	3rd party tested	3rd party tested	3rd party tested
	Code-compliant & safety tested	Code-compliant & safety tested	Code-compliant & safety tested
	Fire tested	Fire tested	Fire tested

For more information about Mitrex eFacade products, visit [mitrex.com](http://mitrex.com) or email us at [info@mitrex.com](mailto:info@mitrex.com)



• **Toll Free**  
+1 (855) 254-0214

• **Learn More**  
[mitrex.com](http://mitrex.com)  
[info@mitrex.com](mailto:info@mitrex.com)

• **Headquarters**  
41 Racine Rd, Toronto, ON M9W2Z4, Canada  
+1 (416) 497 7120

• **USA Office**  
Chrysler Building, 405 Lexington Avenue Floor 26, New York, USA, 10174  
+1 (646) 583 4486

Mitrex and Cladify Projects

