



≡ - Facade LITE

Installation Manual
Open Joint System

 MITREX™



Mitrex Solar eFacade LITE

Table Of Contents

Safety Precautions & Handling Of Modules	P. 4
eFacade LITE - Plug & Power Up	P. 5
System Components	P. 6
Fastener Information	P. 8
Fastener Information - ⚡Large Mitrex SunTile	P. 8
Fastener Information - ⚡Small Mitrex SunTile	P. 9
Product Installation	P. 10
eFacade LITE Add-On	P. 25
Minimum Cuttable SunTile Area & Anchor Plate Positioning	P. 27
Cutting eFacade LITE Add-On Modules	P. 28
Product Installation - eFacade LITE Add-On	P. 34
Layout Inspiration	P. 43

Safety Precautions & Handling Of Modules

The following instructions relate to the safety and intended use of PV modules. Failure to comply with any instructions below may result in product damage, physical injury and/or death.

Manual Disclaimer

The information presented in this manual is subject to change by Mitrex without prior notice. Mitrex gives no warranty of any kind whatsoever, either explicitly or implicitly, with respect to the information herein. In the case of any inconsistency between different language versions, the English version shall overcome and take control in all respects.

eFacade LITE - Plug & Power Up

eFacade LITE is transforming the building-integrated photovoltaic industry with its cutting-edge design and flawless integration. With no visible wiring and a simple plug-and-power setup, eFacade LITE ensures fast and cost-effective installation.

Available in two sizes and five colors, it harmonizes effortlessly with Cladify sustainable cladding, EIFS, stucco, ACM, and many other materials and finishes—making it an ideal choice for modern architectural projects. Combining advanced solar technology with effortless installation, Mitrex eFacade LITE delivers performance, beauty, and sustainability in one sleek package.

Product Scalability

Mitrex eFacade LITE is a lightweight, high-performance cladding solution designed for easy adaptation across a wide range of building types and sizes. Its reduced weight makes it ideal for retrofits, mid-rise buildings, and load-limited structures, while its modular panels enable faster installation and lower labor costs. With flexible design options, eFacade LITE delivers solar integration, design versatility, and cost-effective deployment — for both new builds and retrofits.

Plug & Power, Simplified Wiring

- Eliminate panel-to-panel wiring
- Streamlined solar systems

Easy Installation

- Pre-engineered for optimal performance, ease, and aesthetic appeal
- Quick to install, making a big impact in no time

Design Versatility

- 150 SQFT of solar material with a variety of architectural configurations
- 5 colors and texture finishes available

Sizing Options

- Choose from 73 × 36 in (1,854 × 922 mm) or 73 × 18 in (1,854 × 456 mm) modules
- Modular design for customizable building solutions

Long-Lasting Confidence

- Backed by a 25-year product and energy performance warranty

Applications

- Ideal for both new constructions and retrofits
- High-performance rainscreen system – one complete solution for all your needs

Sustainable Energy Generation

- Power range of 10 to 18 W/SQFT

System Components

This package contains enough material to construct 150 SQFT of wall.

Components Details

ID	Piece	Specs
1.	⚡ Large Mitrex SunTile	Check Mitrex eFacade LITE datasheet
2.	⚡ Small Mitrex SunTile	Check Mitrex eFacade LITE datasheet
3.	Support Bar	Aluminum Alloy
4.	⚡ Power Bar A With Microinverter	Aluminum Alloy
5.	⚡ Power Bar	Aluminum Alloy
6.	Anchor Plate	Aluminum Alloy
7.	SunTile Rivets	Butterfly rivet 3/16"
8.	System Screws	#10 × 3/4 in pan head self-drilling screw
9.	Wall Screws	Depends on wall

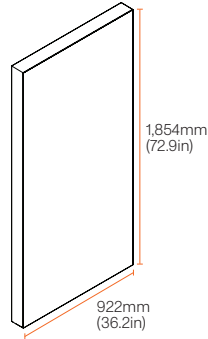

1. ⚡ Mitrex SunTile Large

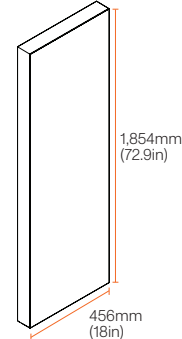

2. ⚡ Mitrex SunTile Small

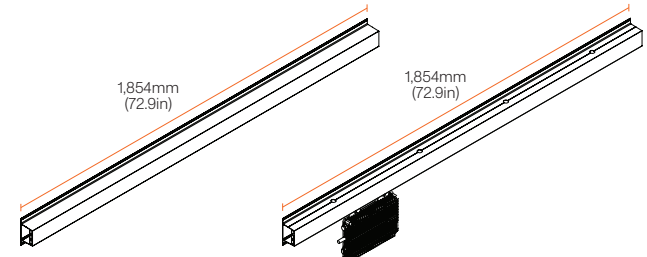

3. Support Bar

4. ⚡ Power Bar A

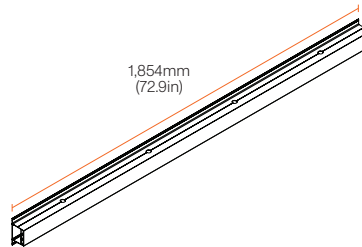

5. ⚡ Power Bar B

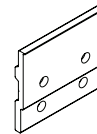

6. Anchor Plate

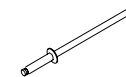

7. SunTile Rivets



8. System Screws



Mitrex Solar eFacade LITE

Fastener Information - ⚡ Large Mitrex SunTile Extruded Aluminum Profile - Anchor Plate (AP)

Portrait Installation

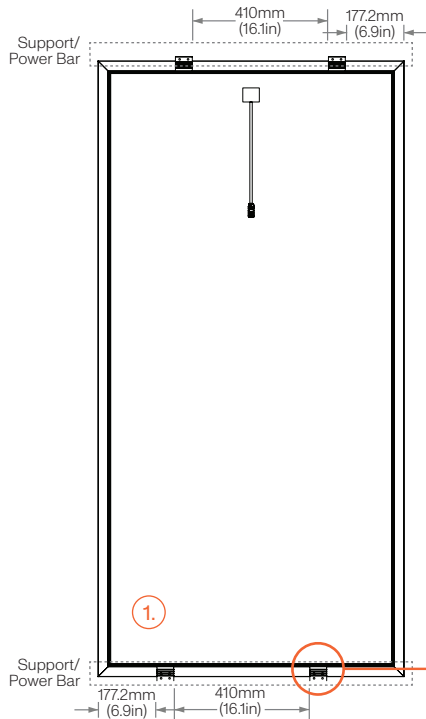

Landscape Installation

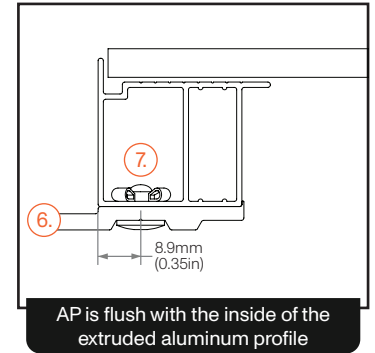
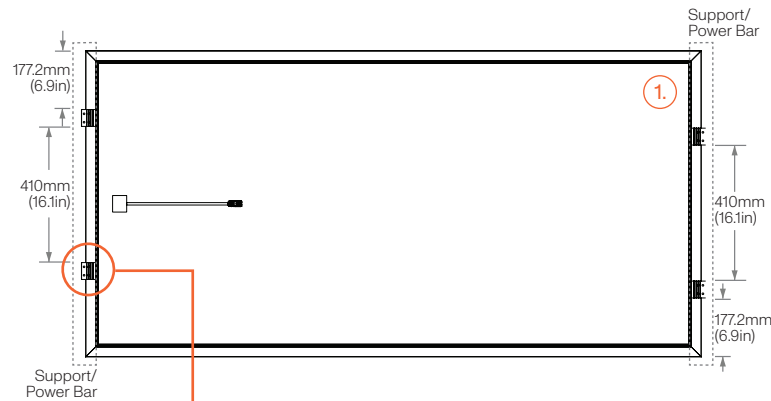

Fastening Material	Quantity Per Module
Butterfly Rivets	8
Anchor Plate	4

Fastener Information - ⚡ Small Mitrex SunTile Extruded Aluminum Profile - Anchor Plate (AP)

Portrait Installation

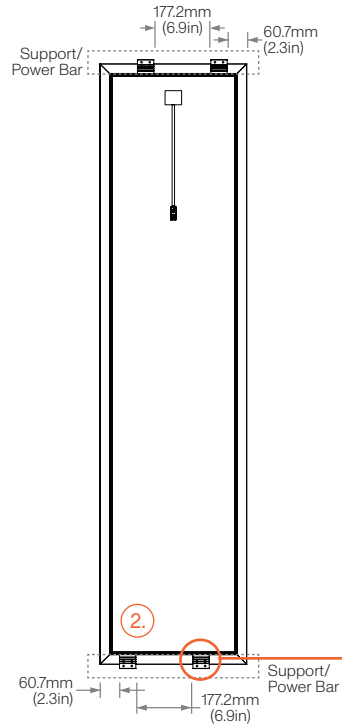

Landscape Installation

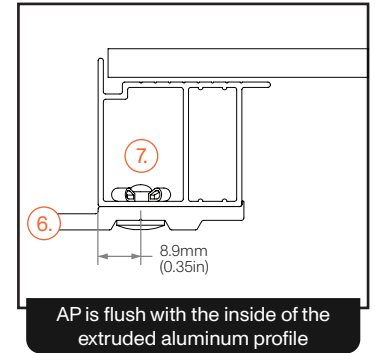
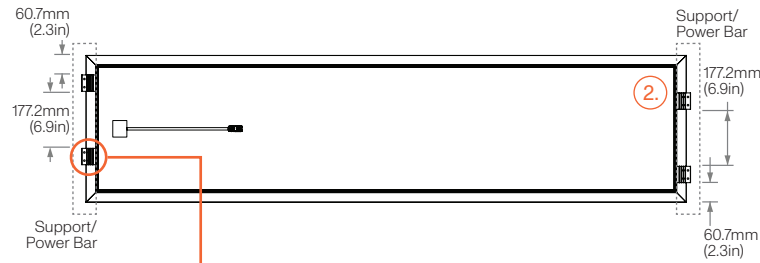

Fastening Material	Quantity Per Module
Butterfly Rivets	8
Anchor Plate	4

Product Installation

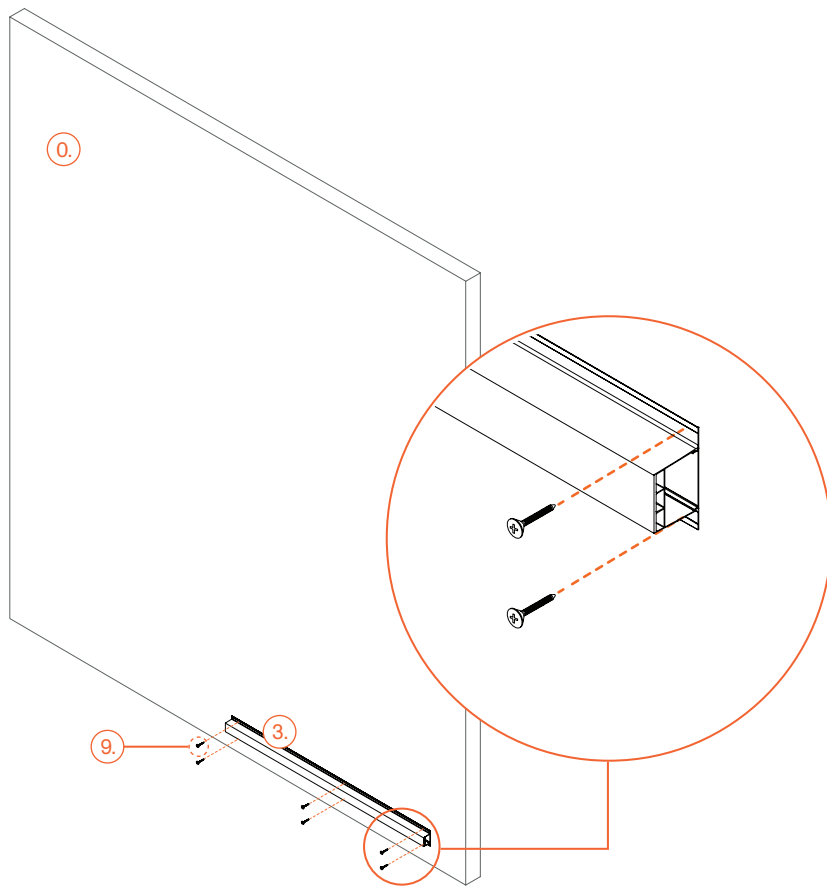

1. Measure and level the first Support Bar from the bottom of the wall.
2. Fasten the Support Bar. Depending on the wall material, select the appropriate screws.

● Components Guide

- 0. Wall
- 3. Support Bar
- 9. Wall Screws

For information on screw types for different walls, check the Mitrex downloads section.



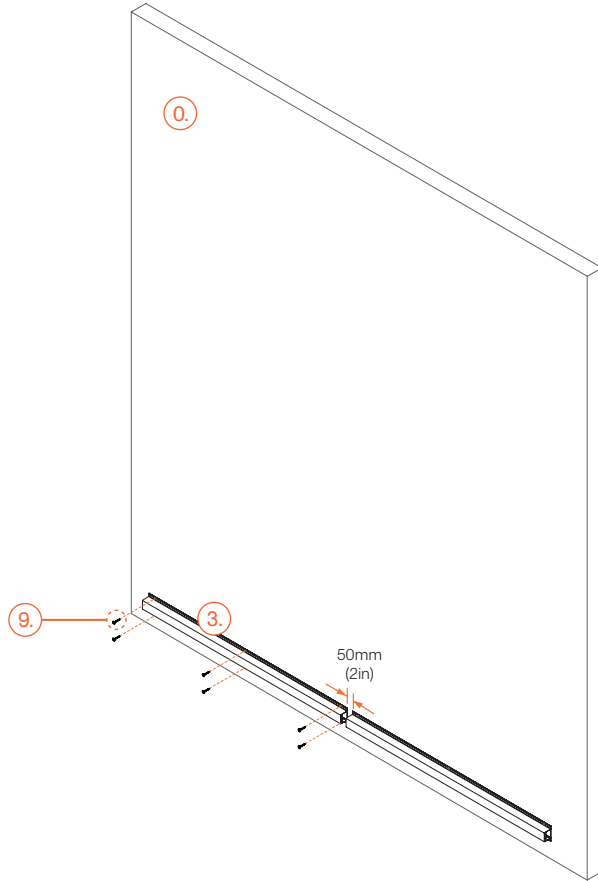

1. Measure and level the second Support Bar from the bottom of the wall and at 50 mm (2 in) away from the first Support Bar
2. Fasten the Support Bar. Depending on the wall material, select the appropriate screws.

● Components Guide

- 0. Wall
- 3. Support Bar
- 9. Wall Screws

For information on screw types for different walls, check the Mitrex downloads section.



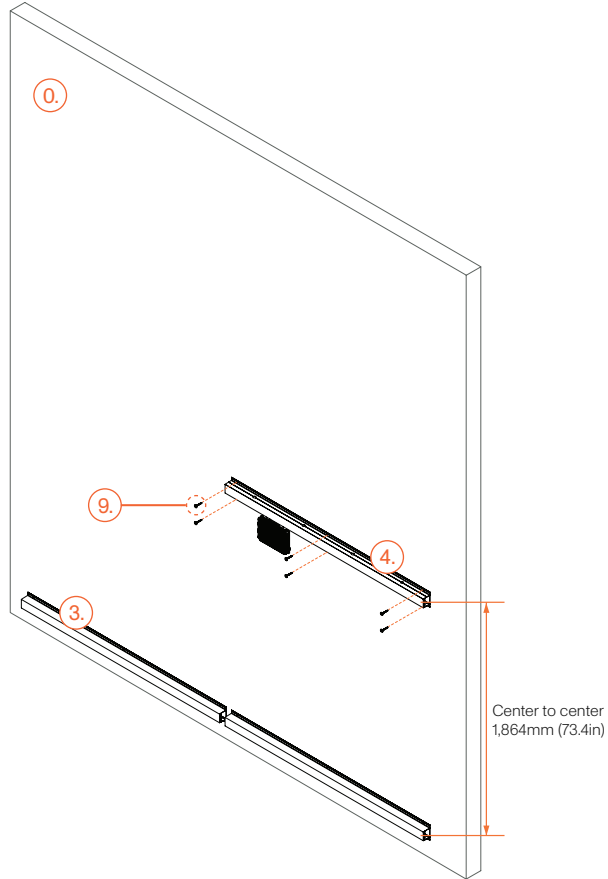

1. From center to center, measure 1,864 mm (73.4 in) and level the Power Bar A (has microinverter).
2. Fasten the Power Bar A. Depending on the wall material, select the appropriate screws.

● Components Guide

- 0. Wall
- 3. Support Bar
- 4. ⚡ Power Bar A
- 9. Wall Screws

For information on screw types for different walls, check the Mitrex downloads section.



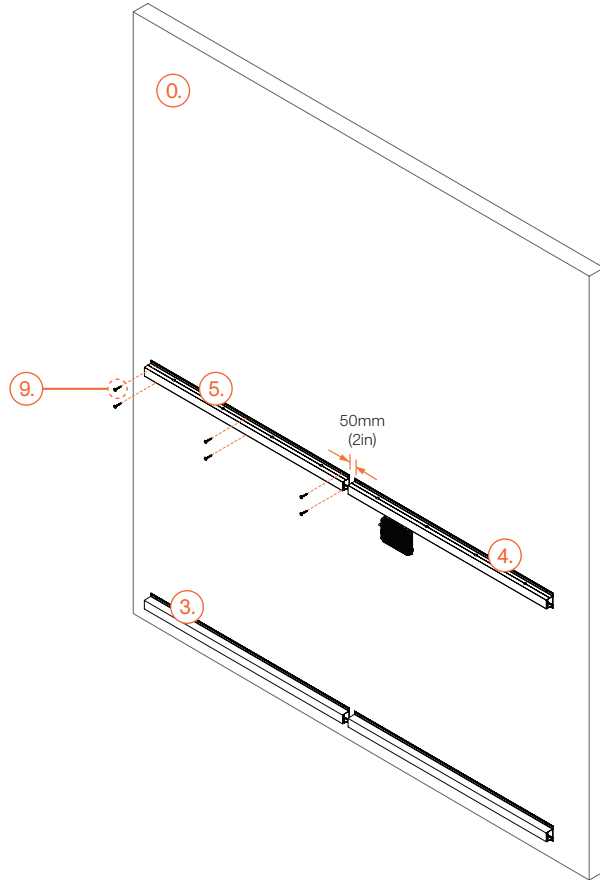

1. Measure and level the Power Bar B.
2. Fasten the Power Bar B 50 mm (2 in) away from Power Bar A.
3. Depending on the wall material, select the appropriate screws.

● Components Guide

- 0. Wall
- 3. Support Bar
- 4. ⚡ Power Bar A
- 5. ⚡ Power Bar B
- 9. Wall Screws

For information on screw types for different walls, check the Mitrex downloads section.



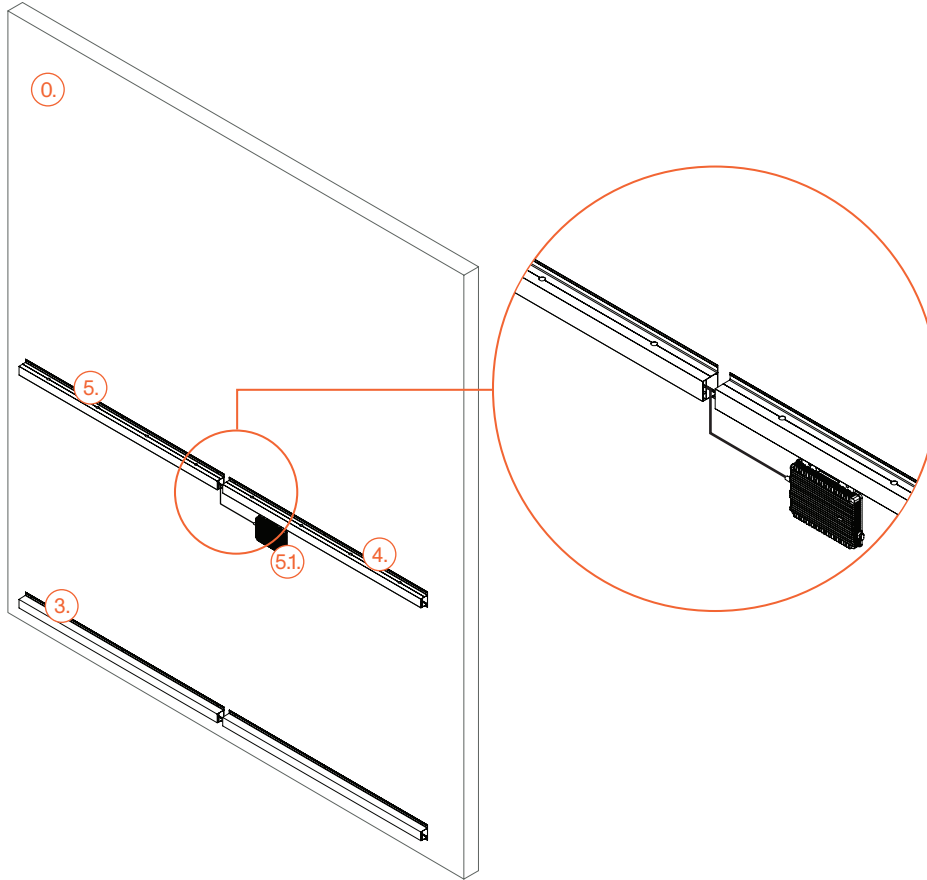

1. Connect the wires in Power Bar B to the microinverter on Power Bar A.

● Components Guide

- 0. Wall
- 3. Support Bar
- 4. ⚡ Power Bar A
- 5. ⚡ Power Bar B
 - 5.1. Microinverter

For information on screw types for different walls, check the Mitrex downloads section.



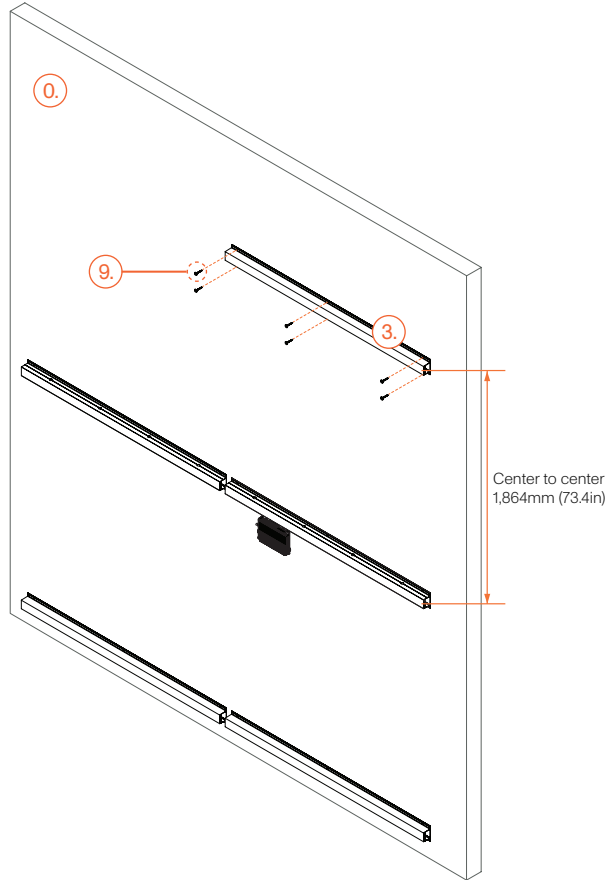

1. From center to center, measure and level the Support Bar.
2. Fasten the Support Bar. Depending on the wall material, select the appropriate screws.

● Components Guide

- 0. Wall
- 3. Support Bar
- 9. Wall Screws

For information on screw types for different walls, check the Mitrex downloads section.



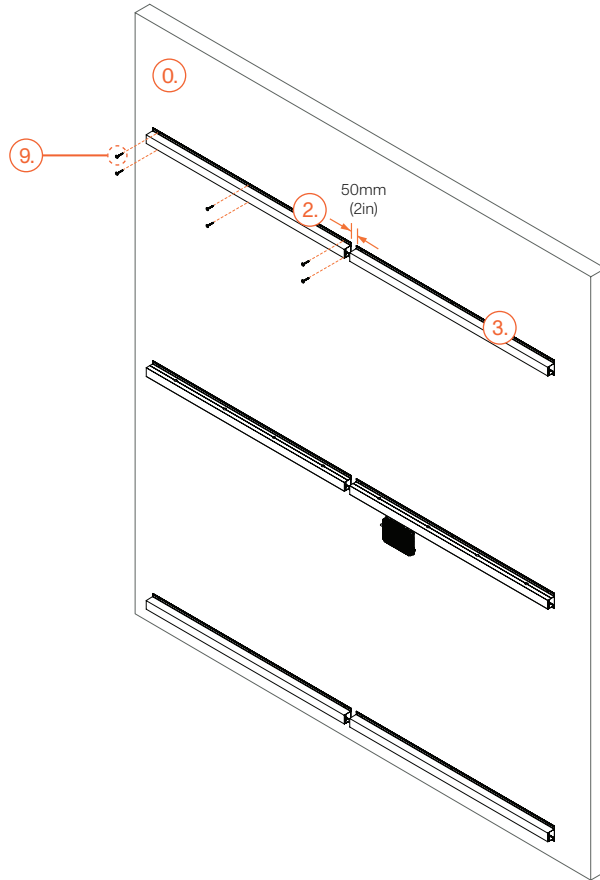

1. From center to center, measure and level the Support Bar.
2. Fasten the Support Bar 50 mm (2 in) apart from the first Support Bar.
3. Depending on the wall material, select the appropriate screws.

Note:

- The AC trunk cable needs to be run before installing the SunTiles - See page 23
- For connecting multiple 150 SQFT systems - See page 23

● Components Guide

- 0. Wall
- 3. Support Bar
- 9. Wall Screws

For information on screw types for different walls, check the Mitrex downloads section.



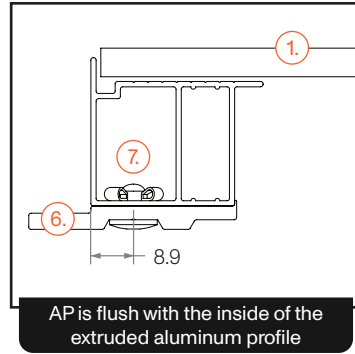
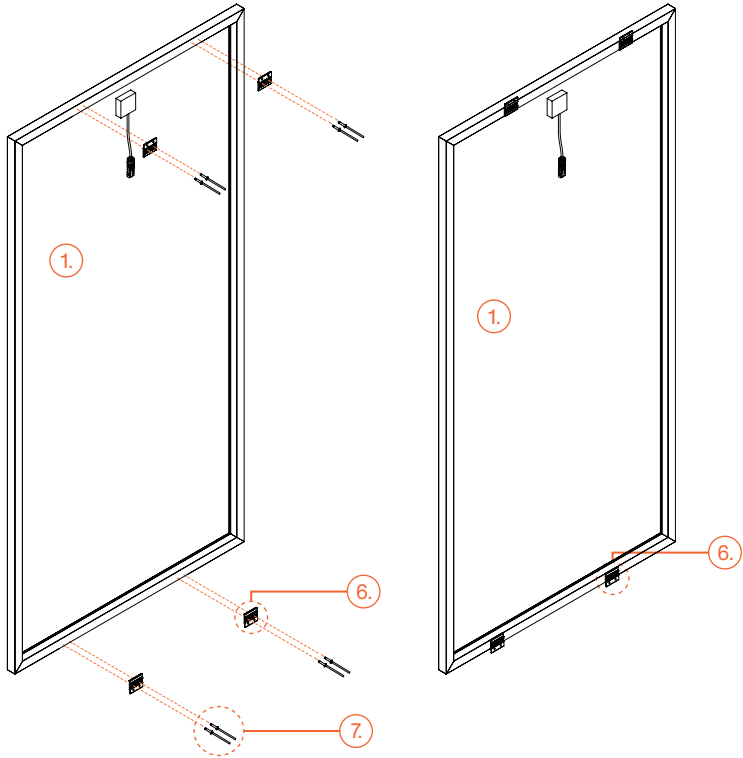

1. Attach the Anchor Plates to the SunTile's extruded aluminum profile using the butterfly rivets. See page 8-9.

● **Components Guide**

- 1. ⚡ Large Mitrex SunTile
- 6. Anchor Plate
- 7. SunTile Rivets (Butterfly Rivets)

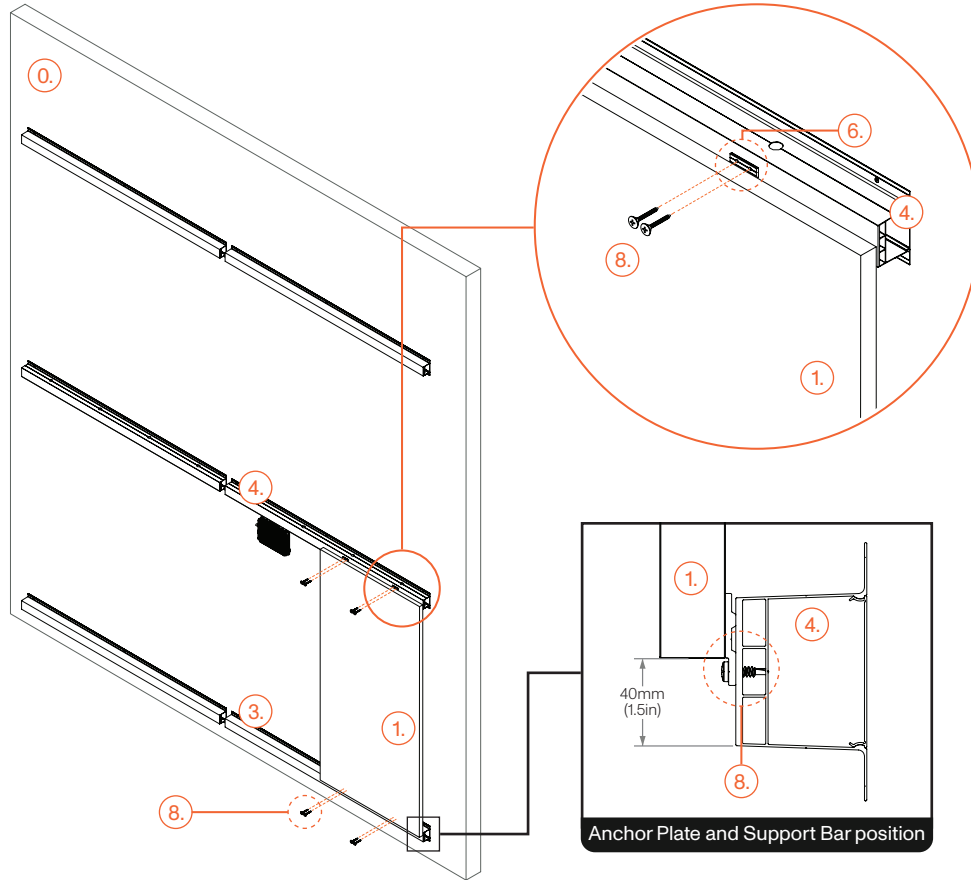

1. Once placed, fasten the first SunTile using the provided System Screws. Follow the measurement shown in the drawing.

● Components Guide

- 0. Wall
- 1. ⚡ Large Mitrex SunTile
- 3. Support Bar
- 4. ⚡ Power Bar A
- 6. Anchor Plate
- 8. System Screws

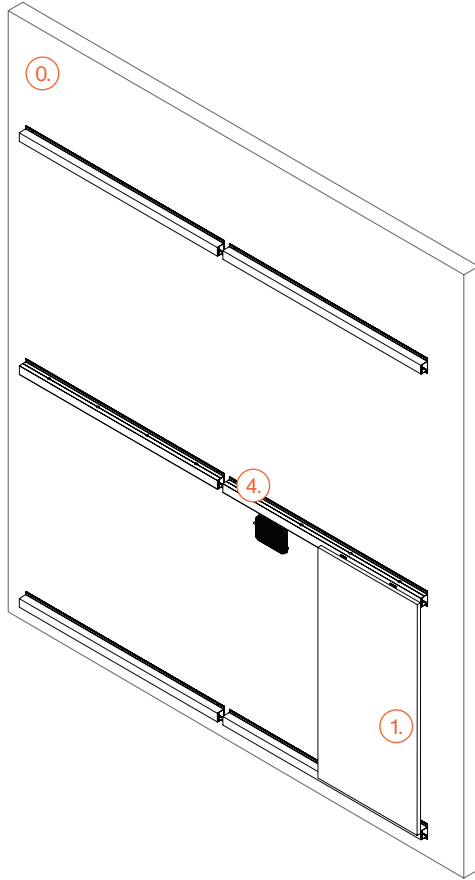

1. Reach for the single wire coming out from the SunTile and connect it to the closest entry in the Power Bar until you hear a "Click".

Note: Each panel needs to be connected to the closest plug in the Power Bar.

● Components Guide

- 0. Wall
- 1. ⚡ Large Mitrex SunTile
 - 1.1 SunTile Connector
- 4. ⚡ Power Bar A

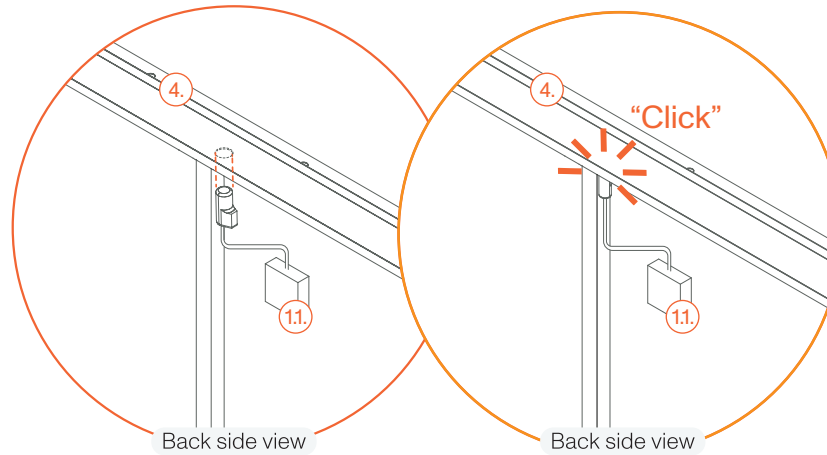

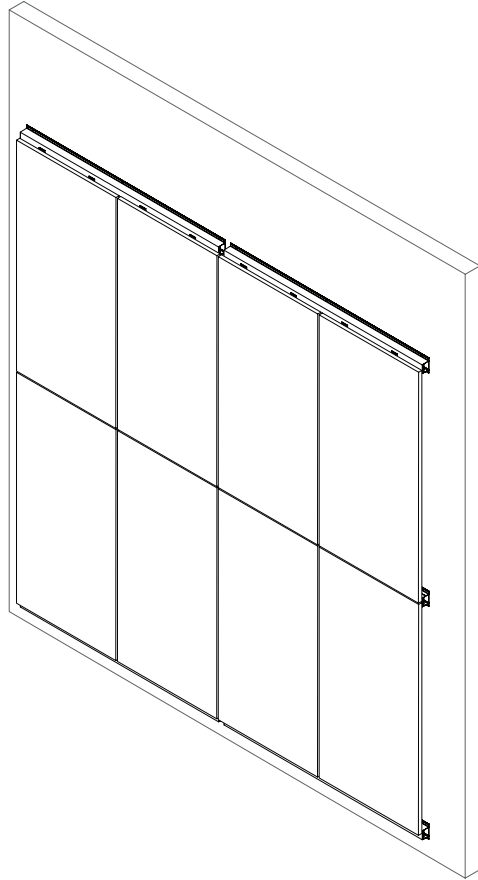

1. Repeat the process until all 8 SunTiles are installed.
2. Please note that this is an open joint system.

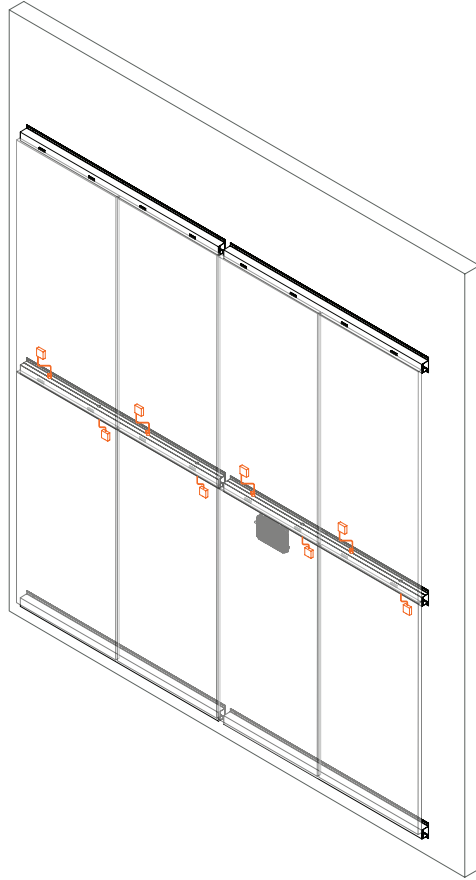

1. Each panel needs to be connected to the closest plug in the Power Bar.

Wall To Wall Scenario

When you are connecting one 150 SQFT system to another one, you need to connect the microinverters in the power bars with an AC trunk cable.

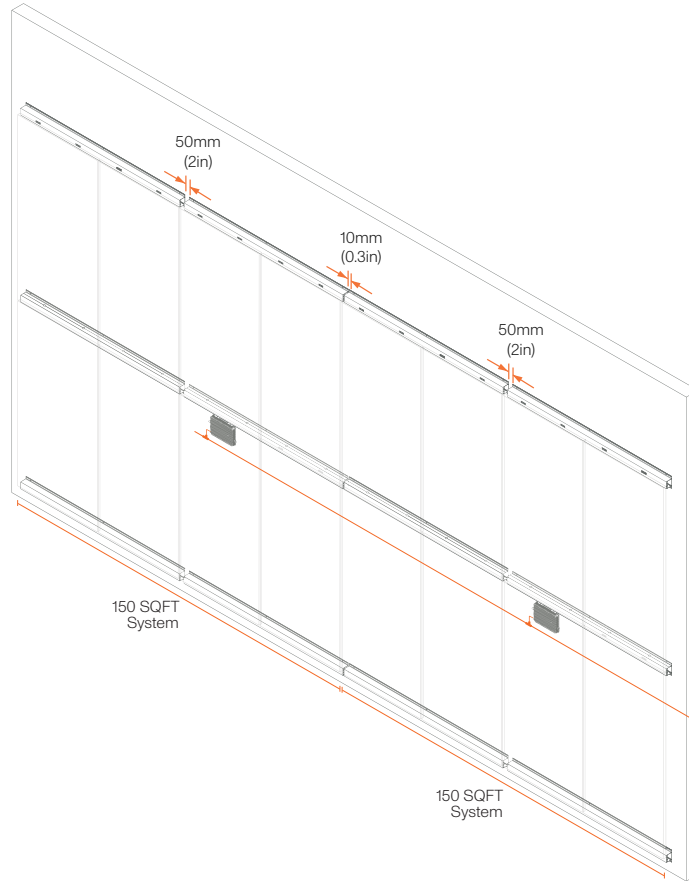

1. When installing multiple 150 SQFT systems side by side, maintain a 10mm (0.3in) gap between the Support and Power Bars of adjacent systems.

Note: The AC trunk cable needs to be run before installing the SunTiles. See page 17.

● Max Number Of Microinverters Per Circuit

480 V	Up to 11 Microinverters
208 V	Up to 6 Microinverters

Wall To Electrical Panel Scenario

When you reach the end of the circuit, you need to connect the microinverter in the power bar to the building electrical panel with an AC trunk cable. You will need to consult a registered electrician.

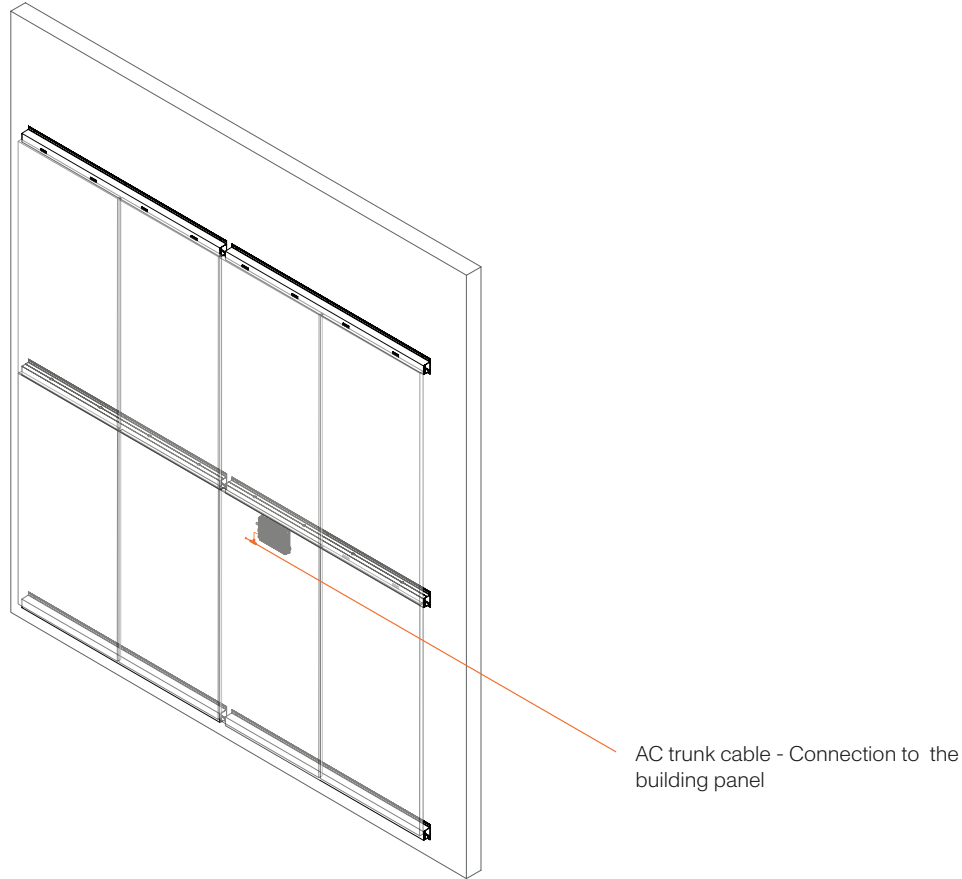

eFacade LITE Add-On

Completing Wall Edges And Corners

eFacade LITE Add-On

To ensure a clean and complete installation, non-active filler modules are available upon request. These modules are designed to integrate seamlessly with the eFacade LITE SunTile modules and can be cut to size on site, allowing installers to finish wall edges and corners with precision.

This flexibility ensures a consistent and professional appearance across the entire facade, regardless of the specific dimensions or geometry of the installation area.

Components Details

ID	System piece	Piece specs
3.	Support Bar	Aluminum Alloy
7.	SunTile Rivets	Butterfly rivet 3/16"
8.	System Screws	#10 × 3/4 pan head self-drilling screw
10.	Non-Active Large Mitrex SunTile	Check Mitrex eFacade LITE datasheet
11.	HC Anchor Plate	Aluminum Alloy



Scan this QR code and learn how to cut these modules on-site.

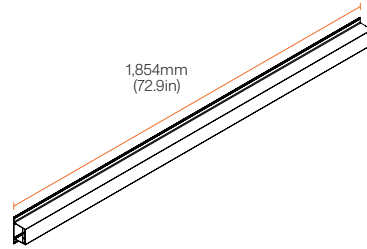

3. Support Bar

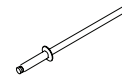

7. SunTile Rivets



8. System Screws

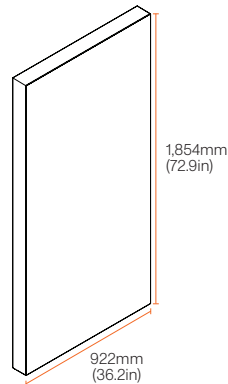

10. Non-Active Mitrex SunTile Large

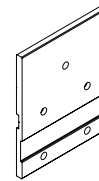

11. HC Anchor Plate

Minimum Cuttable SunTile Area & Anchor Plate Positioning

The minimum SunTile cuttable size is 317.5mm (12.5in) wide and 127mm (5in) tall.

The Anchor Plate Position diagram (shown right) illustrates the mounting hardware layout. Each plate is offset 3.1mm (0.125") from the imaginary line positioned $x/4$ from the nearest vertical edge.



Scan this QR code and learn how to cut these modules on-site.

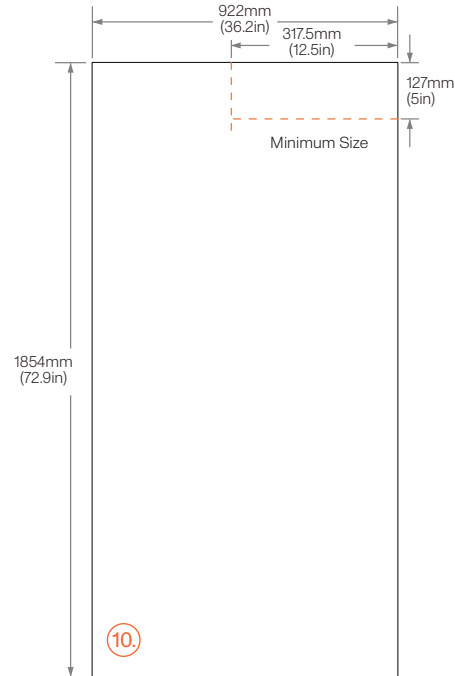

Mitrex SunTile Large

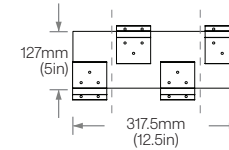

Minimum Size Anchor Plate Position

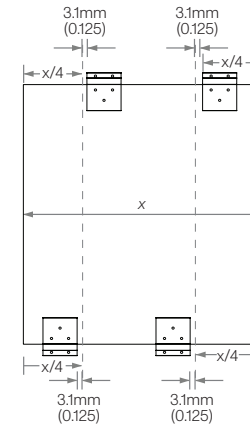

General Logic Anchor Plate Position

Cutting eFacade LITE Add-On Modules

1. Mark the desired size

From the back side of the module, measure and mark the required final dimensions.

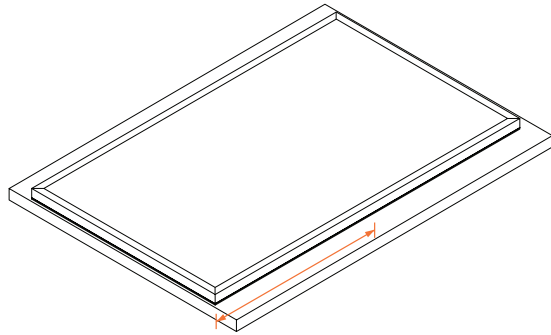
**2. Draw the cutting guide**

Draw a clear, visible line. This line will serve as the cutting guide.

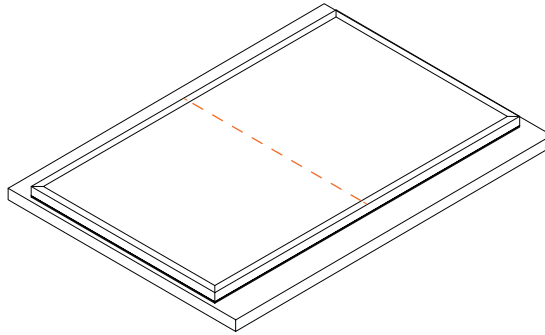
**3. Position protective metallic supports**

Place two metallic support pieces along both sides of the module. These pieces, with a thickness of 6 mm, help protect the glass integrity during the honeycomb cutting process.

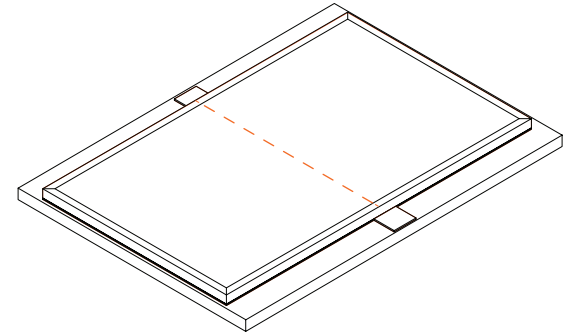

Scan this QR code and learn how to cut these modules on-site.

4. Secure the assembly

Use clamps to firmly secure the module and each metallic support piece. Ensure each support piece is clamped independently to prevent movement during cutting.

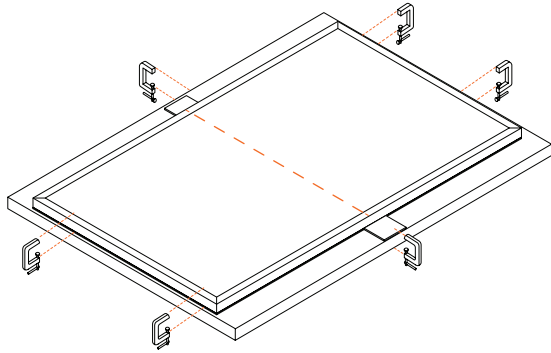

5. Adjust the circular saw depth

Set the blade depth of the circular saw as demonstrated, ensuring proper engagement with the honeycomb and frame without damaging the glass.

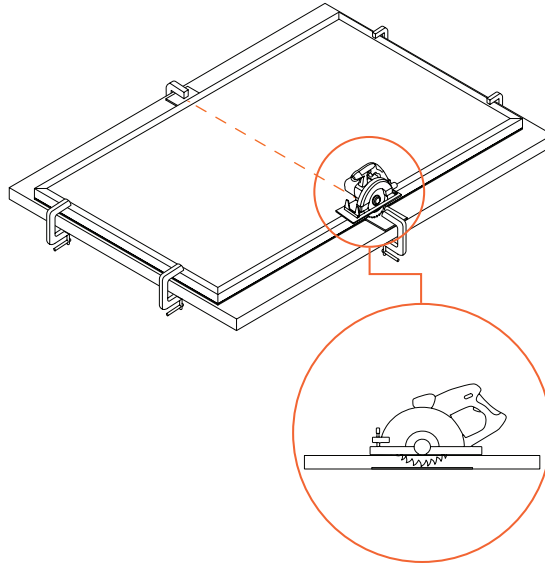

6. Cut the honeycomb

Carefully cut along the marked guideline. Position the blade at the outer edge of the line, not the center, to ensure the final module dimensions remain accurate.

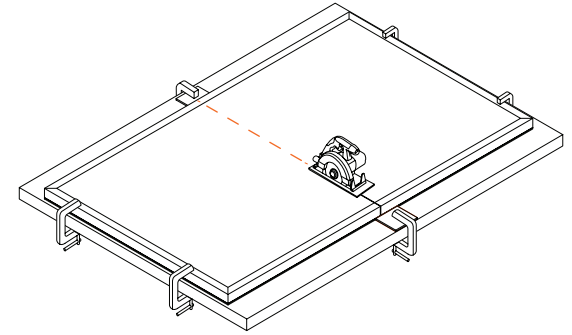

Scan this QR code and learn how to cut these modules on-site.

7. Remove residual EVA

Using a sharp utility knife, cut any remaining EVA material. Keep the blade close to the honeycomb edge corresponding to the final module size.

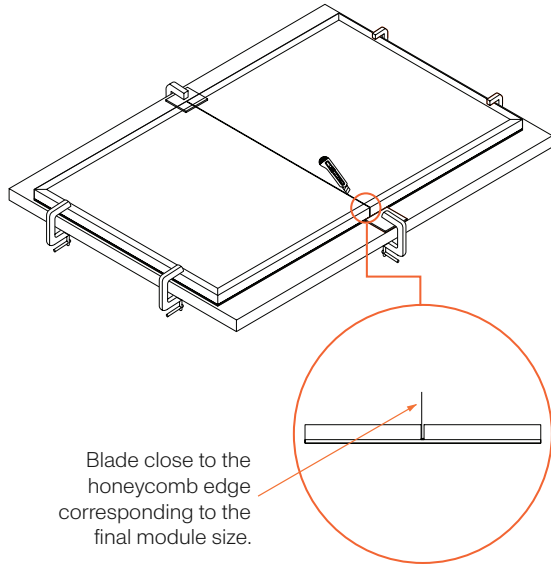
**8. Remove clamps and supports**

Once cutting is complete, carefully remove the clamps and metallic support pieces.

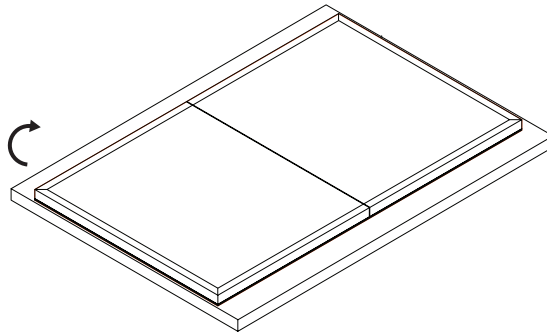
**9. Score the glass**

Align a straight edge with the marked cutting line. Using a glass cutter, score the glass surface in a single continuous motion.

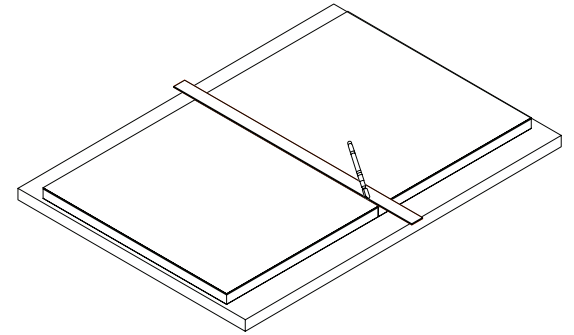

Scan this QR code and learn how to cut these modules on-site.

10. Break the glass cleanly

Position the module at the edge of a stable worktable. Apply controlled, firm pressure to break the glass cleanly along the scored line.

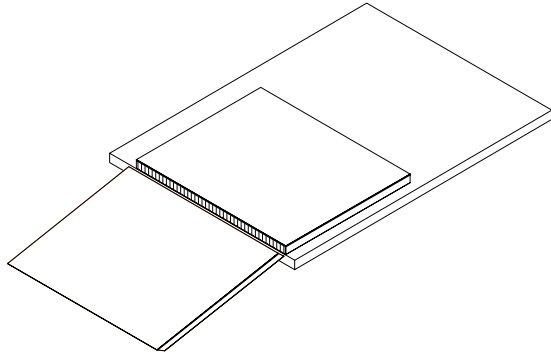
**11. Finish the edges**

Sand all cut edges to remove sharp points and ensure a smooth, safe finish.

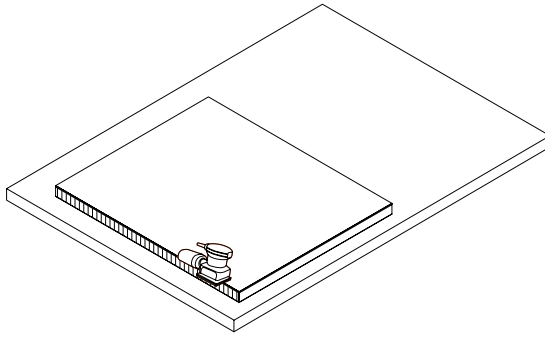
**12. Apply structural silicone**

Apply black structural silicone along the exposed open edge to seal and protect the module.

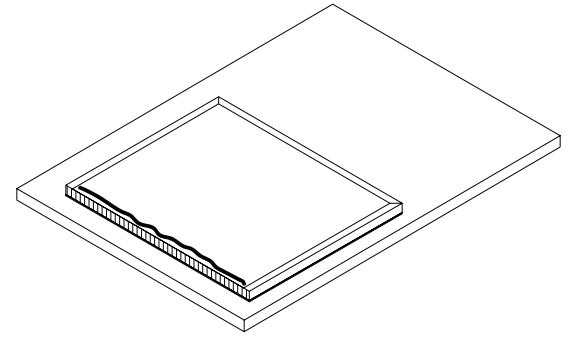

Scan this QR code and learn how to cut these modules on-site.

13. Install the frame closure piece

Attach the pre-cut frame closure piece to the open edge, ensuring proper alignment and full contact with the silicone.

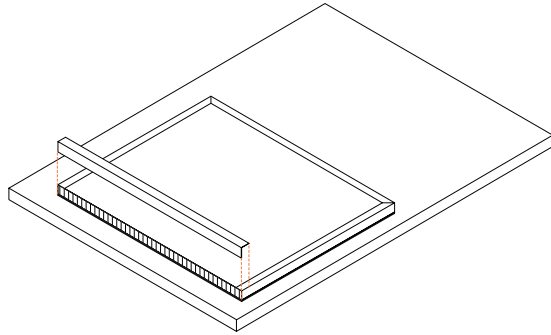
**14. Module ready for installation**

Allow the silicone to cure for 1 hour. Once fully cured, the module is ready for installation.

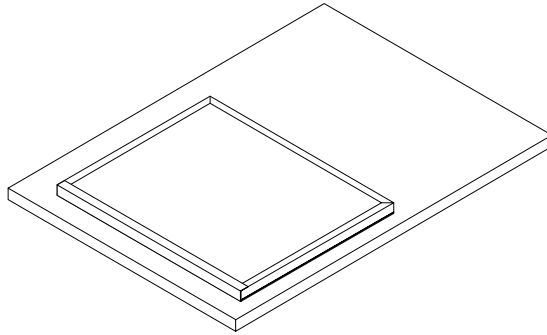

Scan this QR code and learn how to cut these modules on-site.

Product Installation - eFacade LITE Add-On

Completing Wall Edges And Corners

Completing The Wall

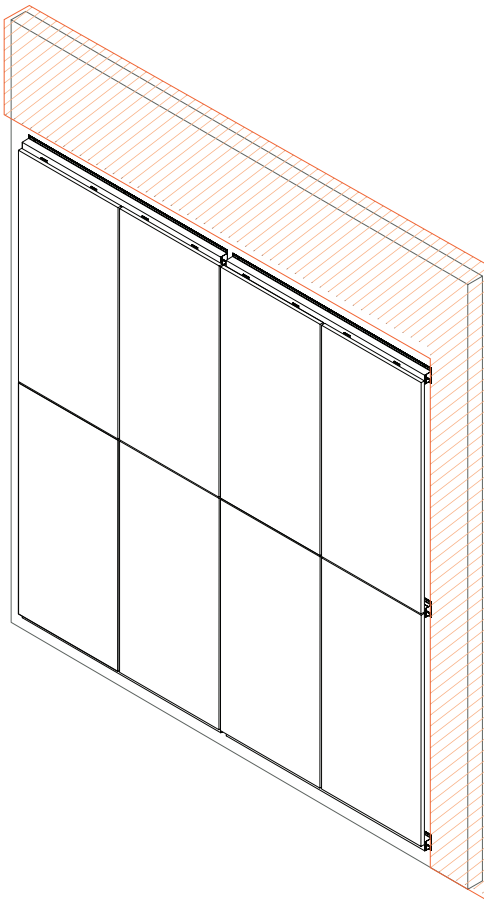

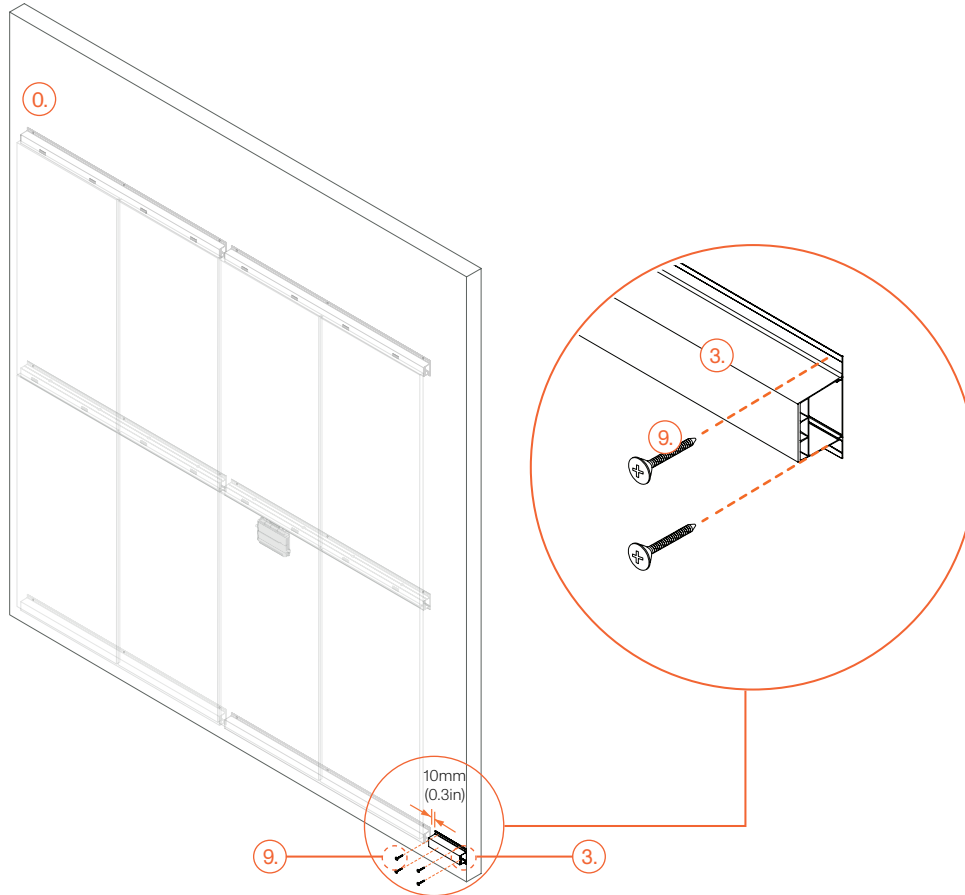

1. Cut the support bar to required size. Leave 10mm (0.3in) gap with adjacent support bar.
2. Measure and level the first cut to size Support Bar from the bottom of the wall.
3. Fasten the Support Bar. Depending on the wall material, select the appropriate screws.

● Components Guide

- 0. Wall
- 3. Support Bar
- 9. Wall Screws

For information on screw types for different walls, check the Mitrex downloads section.



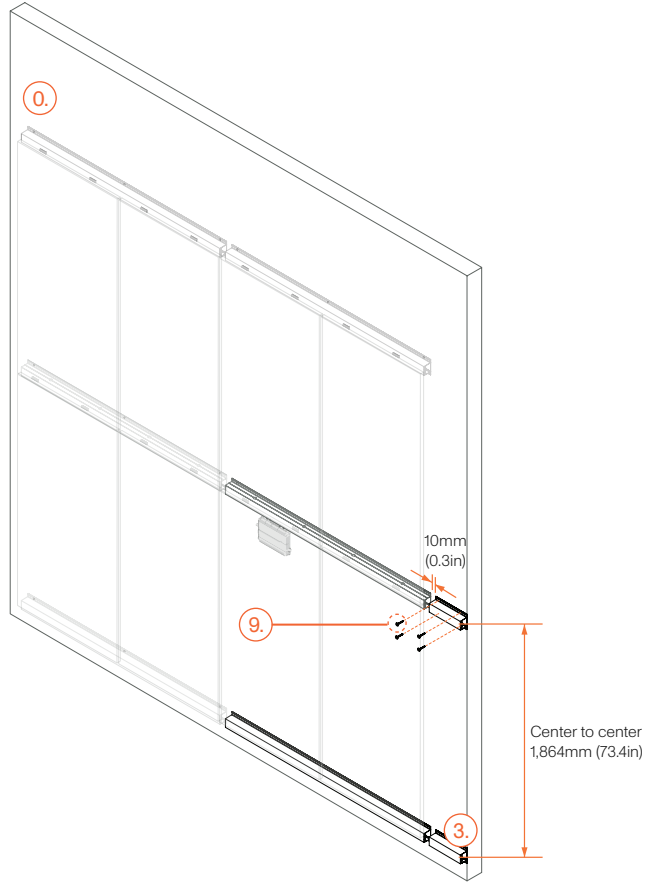

1. From center to center, measure 1,864 mm (73.4 in) and level the cut to size Support Bar.
2. Fasten the cut to size Support Bar 10 mm (0.3 in) apart from the adjacent Support Bar. Depending on the wall material, select the appropriate screws.

● Components Guide

- 0. Wall
- 3. Support Bar
- 9. Wall Screws

For information on screw types for different walls, check the Mitrex downloads section.



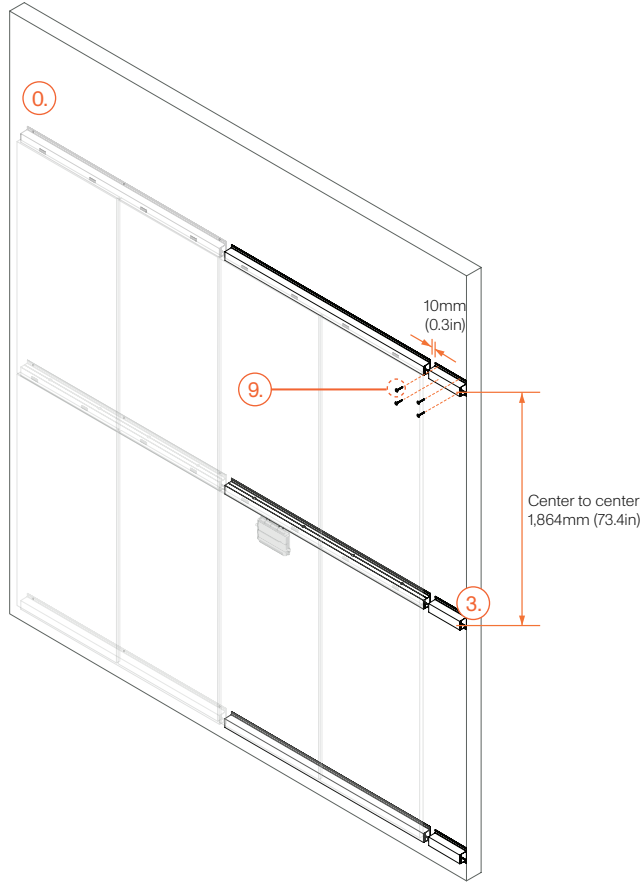

1. From center to center, measure 1,864 mm (73.4 in) and level the cut to size Support Bar.
2. Fasten the cut to size Support Bar 10 mm (0.3 in) apart from the adjacent Support Bar. Depending on the wall material, select the appropriate screws.

● Components Guide

- 0. Wall
- 3. Support Bar
- 9. Wall Screws

For information on screw types for different walls, check the Mitrex downloads section.



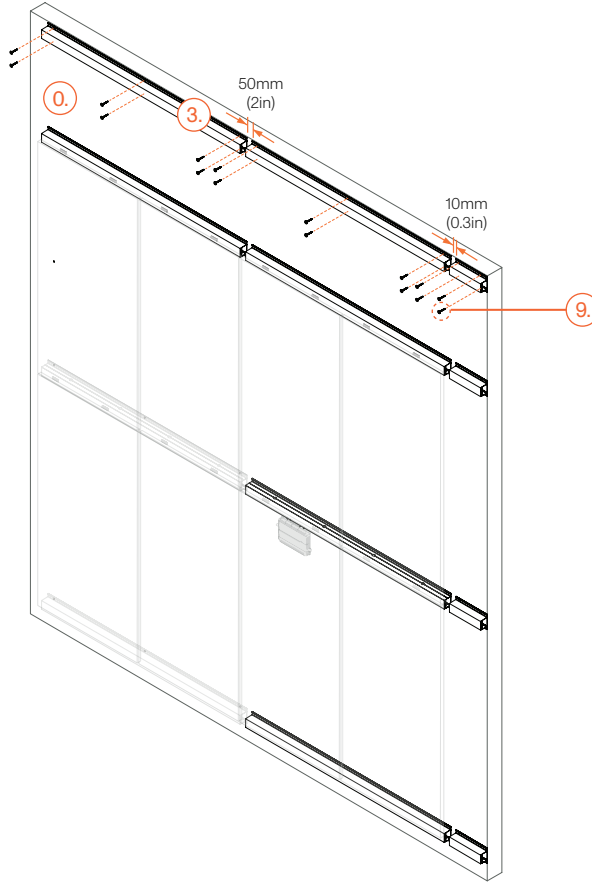

1. Measure and level the top cut to size Support Bars. For the distance between the top Support Bars refer to the drawing.
2. Fasten the Support Bar. Depending on the wall material, select the appropriate screws.

● Components Guide

- 0. Wall
- 3. Support Bar
- 9. Wall Screws

For information on screw types for different walls, check the Mitrex downloads section.



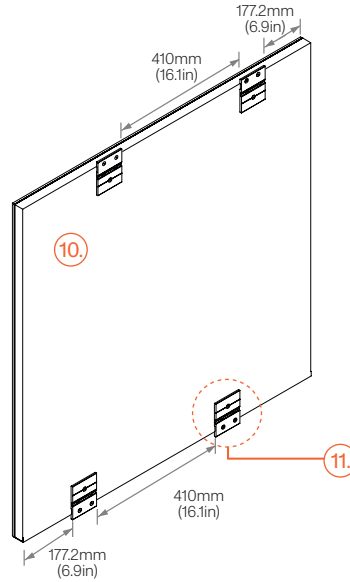
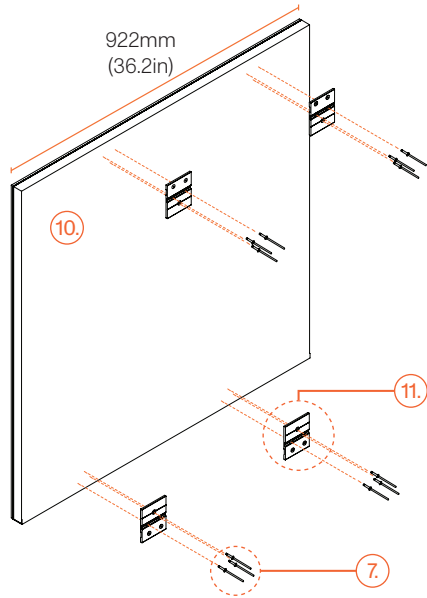

1. Attach the Anchor Plate to the cut on site SunTile using the butterfly rivets.

● Components Guide

- 7. System Rivets (Butterfly Rivets)
- 10. Non-active Cut SunTile
- 11. HC Anchor Plate

Scan this QR code and learn how to cut these modules on-site.



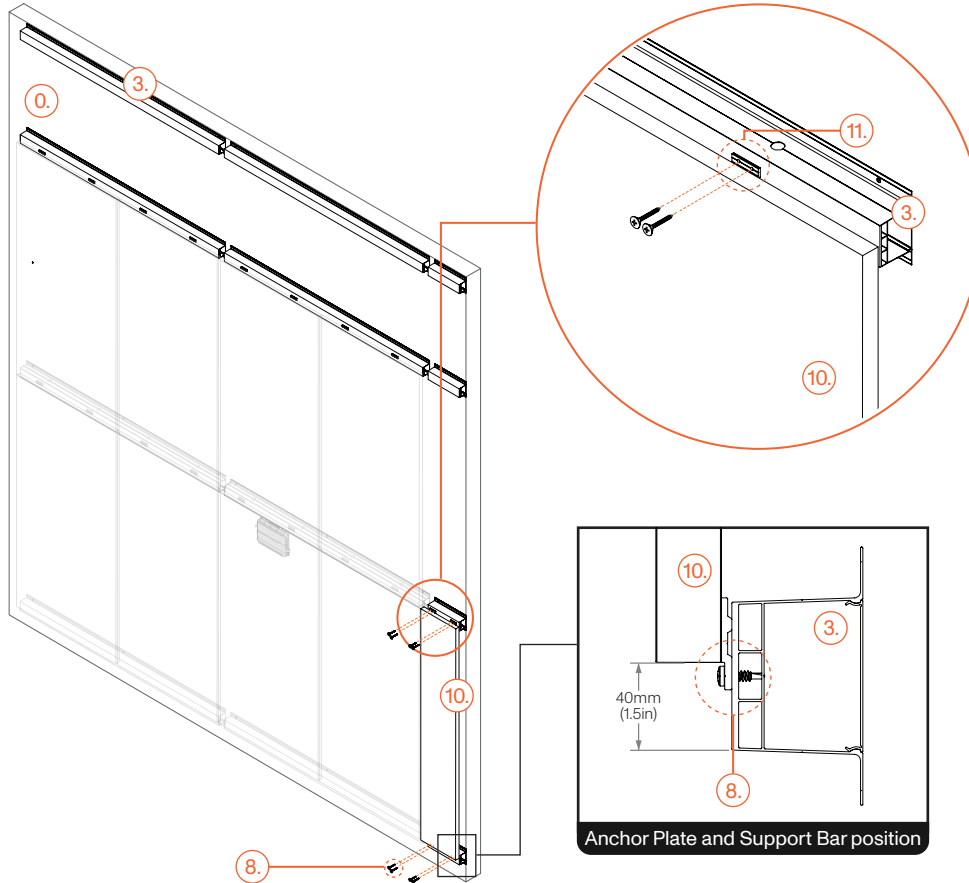

1. Once placed, fasten the first SunTile using the provided System Screws. Follow the measurement shown in the drawing.

● Components Guide

- 0. Wall
- 3. Support Bar
- 8. System Screws
- 10. Non-active Cut SunTile
- 11. HC Anchor Plate

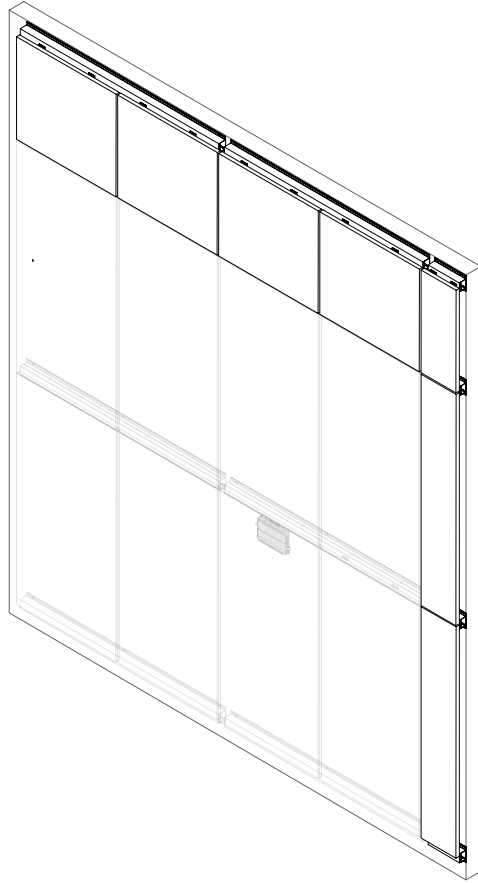

1. Repeat the process until the entire wall is completed.
2. Please note that this is an open joint system.



Scan this QR code and learn how to cut these modules on-site.

Layout Inspiration

● Linear Precision

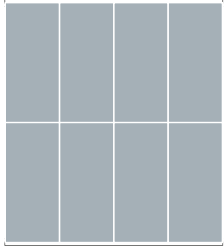

● Horizon Grid

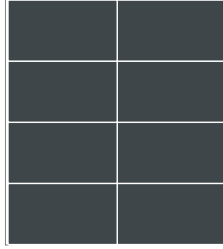

● Half Linear Precision

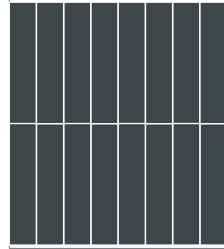

● Half Horizon Grid

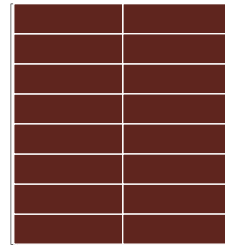

● Dual Linear Precision A

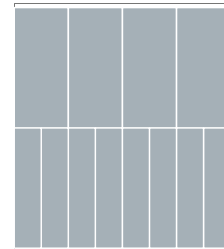

● Dual Horizon Grid

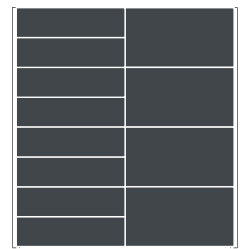

● Mixed Linear Precision

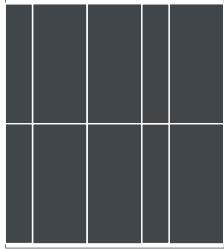

● Mixed Horizon Grid

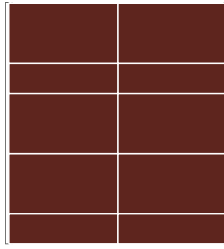

● Dual Linear Precision B

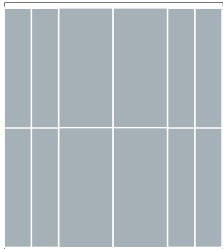

● Dual Linear Precision C

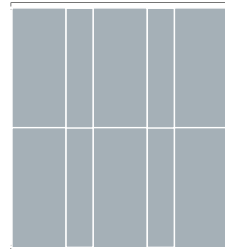

● Dual Linear Precision D

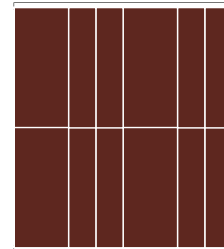

Available Colours



Core Black
⚡ 18W/SQFT



Blackout
⚡ 16W/SQFT



Nobel Grey
⚡ 10W/SQFT



Storm Grey
⚡ 13W/SQFT



Cassia
⚡ 14W/SQFT

- **Toll Free**

+1 (855) 254 0214

- **Learn More**

mitrex.com

info@mitrex.com

- **Headquarters**

41 Racine Rd, Toronto, ON M9W2Z4, Canada

+1 (416) 497 7120

- **USA Office**

Chrysler Building, 405 Lexington Avenue Floor 26, New York, USA, 10174

+1 (646) 583 4486

